

Assembly Instructions

Navi-Trac® Frame Tent

40' Wide System

Please read all assembly / installation instructions before the installation or removal of this product.

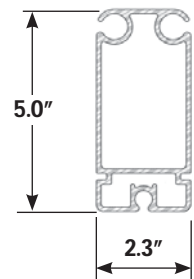

1100 Burch Dr., Evansville, IN 47725
Ph. 812-867-2421 • Fax. 812-867-0547
E-mail: tents@anchorinc.com • www.anchorinc.com

Table of Contents

Page No.	Assembly Step
3	Introduction Inspect Site Frame Terminology
4	Component Illustrations
5	40' Navi-Trac Component List Table Hardware Location Chart
6	Safety Guidelines
7	Squaring the Tent - Footprint Layout
8	Layout End Module Components Construct First Beam
9	Assembling & Completing Hip End Top Frame
10	Summary of Steps for Square Tent Installing Fabric on Hip End Frames
11	Lifting Top Frame
12	Web Guy - Staking Guidelines
13	Tensioning and Guying
14	Hip End Modules for Rectangular Units
15	Units with (1) Middle Bay Installing Mid Bay Purlins and Eave/Ridge Bars
16	Purlin Supports in 20' Mid Bays Installing Mid Panel
17	Units with (2) or more Mid Bays X-Cabled Bays
18	40' Navi-Trac Complete Illustration
19	Wall Installation
20	Ground Bar Keeper
21	Limits of Liability

40' NAVI-TRAC COMPONENT ILLUSTRATIONS

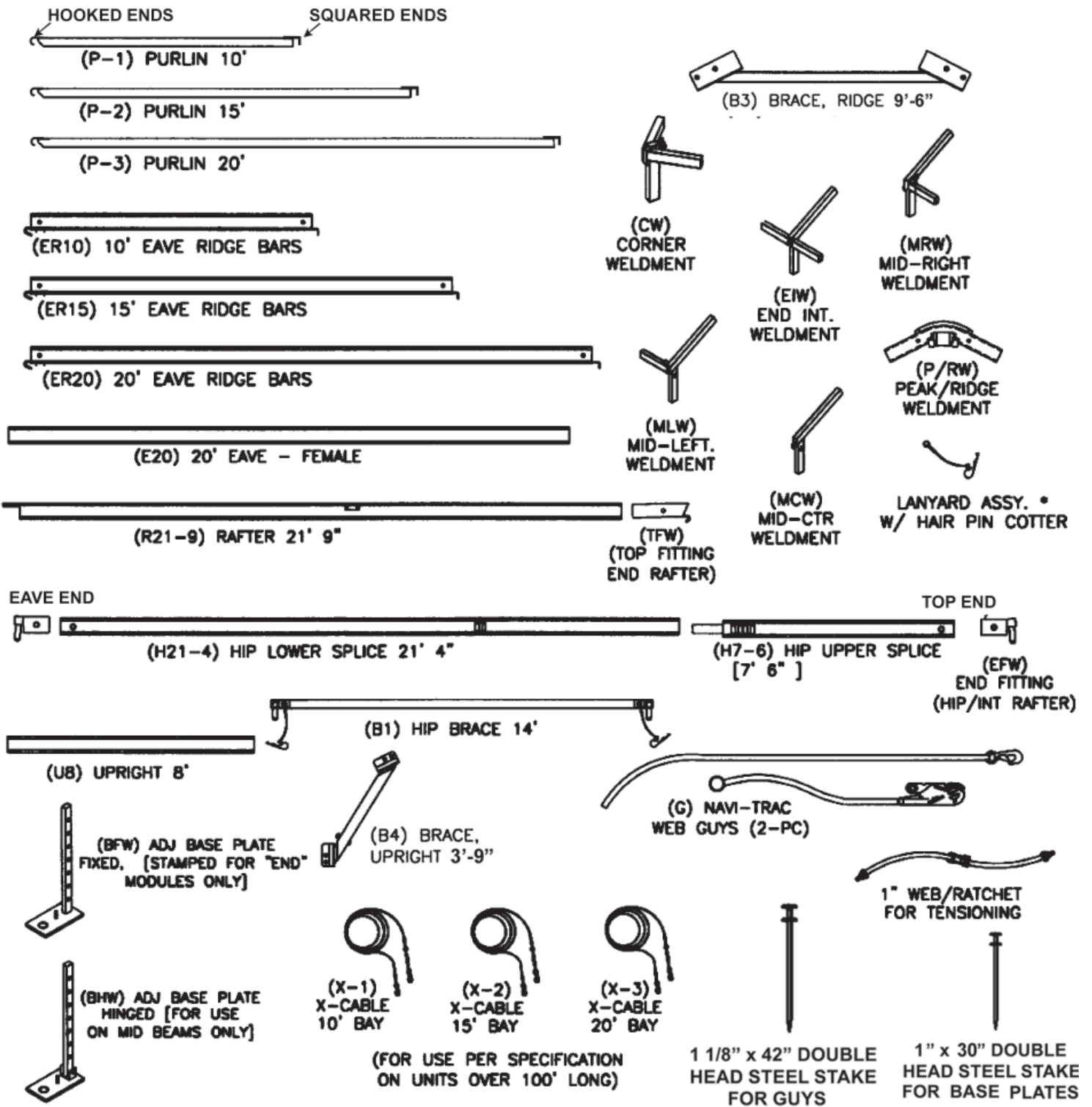

INSTALLATION TOOLS

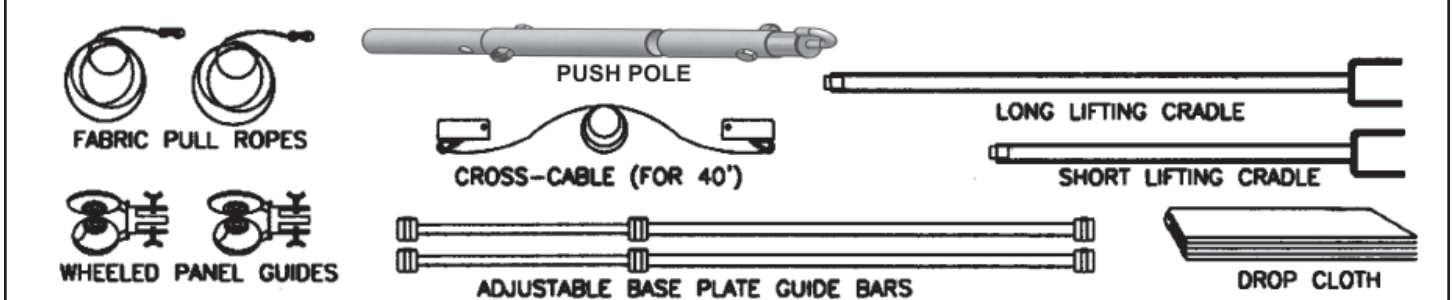

40' NAVI-TRAC COMPONENT LIST

LABEL (LETTER ON DWG)	COMPONENT DESCRIPTION	OTHER I.D. CODES	40 X 40	40' NAVI-TRAC			FRAME		
				20'	20'	15'	15'	10'	10'
				MID	MID	MID	MID	MID	MID
	TOP EXTRUSIONS WITH CHANNELS								
E20	EAVE - FEMALE 20'		8						
ER10	EAVE/RIDGE - DROP-IN 10'							3	3
ER15	EAVE/RIDGE - DROP-IN 15'					3	3		
ER20	EAVE/RIDGE -DROP-IN 20'			3	3				
R21-9	RAFTER 21-9		4	2	2	2	2	2	2
H21-4	HIP LOWER SPLICE (2-PC) 21-4 (40')		4						
H7-6	HIP UPPER SPLICE (2-PC) 7-6 (40')		4						
	BRACES:								
B1	BRACE, HIP 14' [W/ LANYARDS]		8						
B3	BRACE, RIDGE 9'-6"		1	1	1	1	1	1	1
B4	BRACE, UPRIGHTS 3'-9"		4	2	2	2	2	2	2
	PURLINS:								
P1	PURLIN 10'			2	2			2	2
P2	PURLIN 15'					2	2		
P3	PURLIN 20'			2	2				
	UPRIGHTS:								
U8	UPRIGHT 8'		8	2	2	2	2	2	2
	WELDMENTS, FITTINGS & PLATES								
BFW	ADJ. BASE PLATES W/INSERTS (FIXED)	STAMPED "END"	8	2		2		2	
BHW	ADJ. BASE PLATES W/INSERTS (HINGED)				2		2		2
CW	CORNER WELDMENTS		4						
EIW	END INTERMEDIATE. WELDMENTS		4						
MLW	MID LEFT WELDMENTS			2		2		2	
MRW	MID RIGHT WELDMENTS			2		2		2	
MCW	MID CENTER WELDMENTS				2		2		2
RW	PEAK/RIDGE WELDMENT		1	1	1	1	1	1	1
TFW	TOP FITTING (END RAFTER) W/ HDWR		2						
EFW	END FITTING (HIP/INT. RAFTER) W/ HDWR		8						
*	LANYARD ASSY. W/ HAIR PIN COTTER		8						
	INSTALLATION TOOLS:		1						
	CROSS CABLE FOR 40'	BLUE	1	1		1		1	
	LONG LIFTING CRADLE		1						
	SHORT LIFTING CRADLE		1						
	ADJ. BASEPLATE GUIDE BAR		1						
	FABRIC PULL ROPES		2						
	WHEELED PANEL GUIDES		2						
	DROP CLOTH (8' x 30')		1						
	PUSH POLE		1						

OTHER COMPONENT NOTES:

1. FOR X-CABLES FOR UNITS 100' OR LONGER, SEE PAGE 17 FOR LABELING, QUANTITIES, AND INSTALLATION.
2. STAKES AND GUYS ARE NOT INCLUDED IN THIS TABLE. SEE STAKING GUIDELINES ON PAGE 12.

HARDWARE LOCATION CHART

FASTENING HARDWARE & WHERE IT'S USED	30 X 30	30 MID	40 X 40	40' MID	50 X 50	50' MID	CARTON #
TENSION LOCK PINS, 1/2"							
2 ea. End of Knee & Ridge Brace -	0	0	20	12	52	12	No. 11
1 ea. End of Cross Cable	***Included with Cross Cable Carton***						
(some cartons could have greater quantities than are required)							
BOLT 1/2" X 3" W/NYLOCK NUT							
Splices, 2 pc. Hip or Rafter - (attached in splice insert)	0	0	4	0	8	2	w/splice
Top Fitting F/End Rafter -	2	0	2	0	2	0	No. 1
End Fittings F/Hip/Int Rafter -	8	0	8	0	16	0	No. 1 or 6
Uprights - Attach Adjustable Insert	8	2	8	2	16	2	No. 1, 2, 4 or 5
LANYARD Assembly with Hair Pin Cotter							
Ends of Hips	8	0	8	0	8	0	No. 1
Top End of Int Rafter	0	0	0	0	8	0	No. 6
Ends of Braces (Installed at factory)	0	0	16	0	16	0	W/Braces

40' NAVI-TRAC Installation Safety Guidelines

Your installation techniques will evolve to fit the needs of your clients, the experience level of your crews, the nature of other tentage on-site, and the equipment that you have most readily available. We encourage you to begin with a crew of (4) workers and only reduce this number as your experience level allows you to do so safely. Whatever techniques you adapt for your crews, we encourage you to keep safety utmost in mind.

Please read through this assembly manual completely before beginning your installation. Be sure the proper equipment, crew and safety precautions are in place. We hope that you enjoy the design features of the NAVI-TRAC each time the unit is installed.

1. It is recommended that workers wear safety shoes and hard-hats on site.
2. When moving beam sections by hand, use proper lifting techniques to protect the back, and avoid pinching fingers while making hardware connections.
3. Never permit bystanders or uninvolved to stand or walk even briefly in the falling path of a beam as it is being raised or lowered.
4. Be aware to avoid contact of beams with any overhead power lines near the site.
5. When anchoring the structure, avoid all underground power lines and gas lines or other utility easements. Local authorities should be able to map the location of these obstacles.
6. Keep site clear of debris to avoid tripping, especially while carrying components or bundles of fabric.
7. Do not drag bundles of fabric on concrete, asphalt, or ground as this can cause damage to the fabric from abrasion through the bag.
8. When lifting the NAVI-TRAC frame, be sure to use the heavy duty NAVI-TRAC frame lift. The standard Anchor frame lift was not designed for the weight of the NAVI-TRAC frame. When lifting each side of an end section, (2) NAVI-TRAC frame lifts should be used.
9. Before pivoting beams to vertical, clear the area of items that could cause tripping or slipping.
10. Before pivoting each beam, install the cross-cable for safety bracing. Although the cross-cable increases overall strength, on the 40' NAVI-TRAC, it can be removed after assembly, if desired.
11. NOTE: Hinged baseplates should be used only on middle beams supplied as "extensions" and not as a component of an end module. End module plates should all be fixed, and end module eave connections should be rigid, slip joints. Use of hinged baseplates in the end module could cause the end module to collapse during installation.
12. When using ladders to make peak connections, be sure the ladder is tall enough that workers can reach the peak from a ladder step consistent with the safety recommendations for the ladder being used. On middle beams, secure the eaves before climbing the ladder to secure the peak.
13. For any NAVI-TRAC of 100 ft. or more in length, the uprights and rafters of one middle bay must be cross-cabled on both sides in an "X" fashion for each 100 ft. of length (see illustration on page 17).
14. For proper loading and anchoring information, consult the appropriate NAVI-TRAC blueprint available from Anchor Industries Inc.
15. Before installing fabric, verify that all hip, brace, and rafter pins are seated into weldment fittings and secured by lanyard pins.
16. The installation method described herein requires coordination of tasks between workers. A safe installation is dependent on alertness and coordination.
17. Before lifting the top frame to install uprights, **always guy out and stake at least both corners** of the side or end being lifted. This will help maintain the intended footprint and will protect against uplift from the wind that could move or flip the tent, **causing damage to the tent and/or severe injury** to workers.

SQUARING THE TENT FOOTPRINT LAYOUT

LOCATING THE FOUR PRIMARY CORNERS

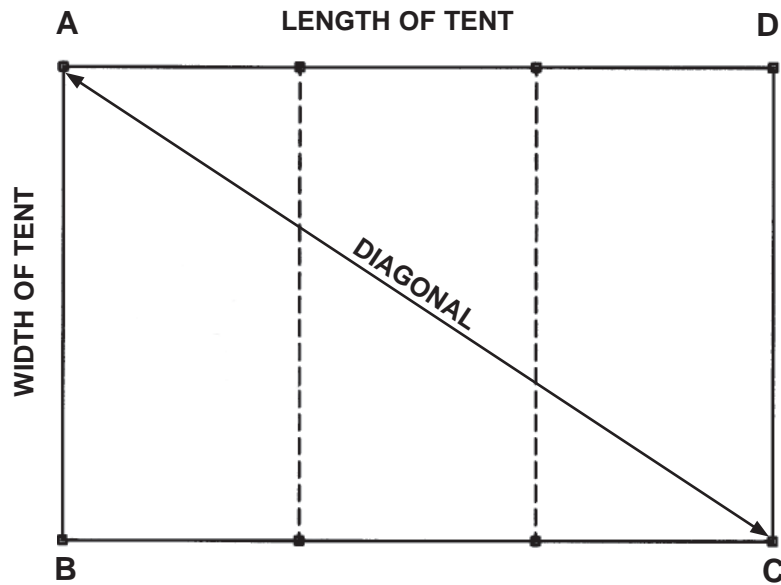

DIRECTIONS FOR SQUARING THE TENT

1. USE A TAPE MEASURE TO MARK THE ENDS OF A LINE FOR ONE END (A TO B ABOVE) EQUAL TO THE EXACT WIDTH OF THE UNIT.
2. HOLD THE "0" END OF ONE TAPE AT POINT "A" AND THE "0" END OF ANOTHER TAPE AT POINT "B".
3. EXTEND THE FIRST TAPE ALONG ONE SIDE OF THE UNIT TO A MEASUREMENT EQUAL TO THE EXACT LENGTH OF THE TENT.
4. CONSULT THE CHART BELOW TO FIND THE DIAGONAL FOR THE TENT YOU ARE BUILDING.
5. EXTEND THE SECOND TAPE TO A MEASUREMENT EXACTLY EQUAL TO THIS DIAGONAL.
6. BRING THE TWO TAPES TOGETHER SO THAT THE LENGTH MEASUREMENT OF ONE LIES DIRECTLY ON THE DIAGONAL MEASUREMENT OF THE OTHER. PULL THE TAPES TIGHT AND MARK THEIR INTERSECTION. THIS WILL LOCATE A FAR CORNER (POINT "C" ABOVE).
7. SWITCH TAPES SO THAT TAPE 1 (ABOVE) MEASURES THE DIAGONAL AND TAPE 2 (ABOVE) MEASURES THE LENGTH. THIS WILL LOCATE POINT "D" ABOVE.
8. WITH THE FOUR PRIMARY CORNERS LOCATED, LAY OUT BASEPLATES AND UPRIGHTS ACCORDING TO THE DIAGRAM TO THE RIGHT AND BEGIN ASSEMBLY, DOUBLE-CHECKING FROM TIME TO TIME TO MAKE SURE THE SQUARE FOOTPRINT IS BEING MAINTAINED.

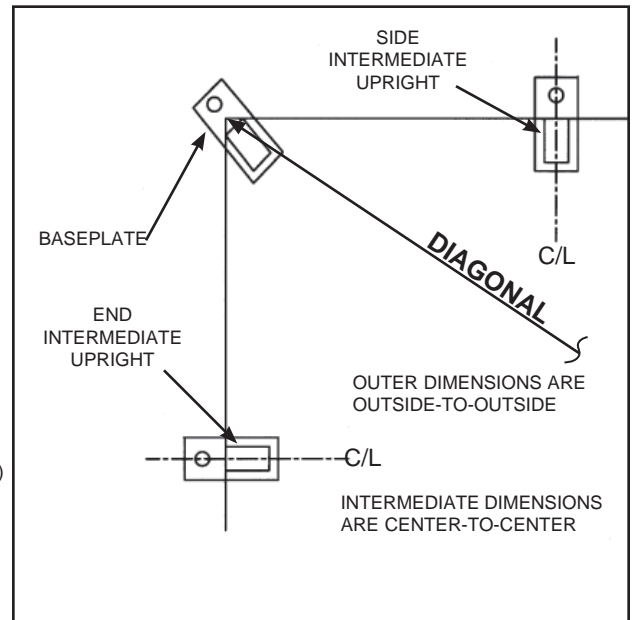

DIAGONALS FOR SQUARING FOOTPRINT

LENGTH OF TENT

FEET	30	40	45	50	55	60	65	70	75	80	85	90	95	100	105	110	115	120	125	130
30	42-5	50-0	54-1	58-4	62-8	67-1	71-7	76-2	80-9	85-5	90-2	94-10	99-8	104-5	109-2	114-0	118-10	123-8	128-7	133-5
40	N/A	56-7	N/A	64-0	68-0	72-1	76-4	80-7	85-0	89-5	93-11	98-6	103-1	107-8	112-4	117-1	121-9	126-6	131-3	136-0
50	N/A	N/A	N/A	70-9	74-4	78-1	82-0	86-0	90-2	94-4	98-7	102-11	107-4	111-10	116-4	120-10	125-5	130-0	134-8	139-3

DIAGONAL SHOWN IN FEET-INCHES (TO NEAREST INCH)

FEET	135	140	145	150	155	160	165	170	175	180	185	190	195	200	205	210	215	220	225	230
30	138-4	143-2	148-1	153-0	157-11	162-9	167-8	172-8	177-7	182-6	187-5	192-4	197-4	202-3	207-2	212-2	217-1	222-0	227-0	231-11
40	140-10	145-7	150-5	155-3	160-1	164-11	169-9	174-8	179-6	184-4	189-3	194-2	199-1	204-0	208-10	213-9	218-8	223-7	228-6	233-5
50	144-0	148-8	153-5	158-1	162-10	167-8	172-5	177-2	182-0	186-10	191-8	196-6	201-4	206-2	211-0	215-10	220-9	225-7	230-6	235-4

WIDTH OF TENT

LAYOUT END MODULE COMPONENTS

NOTE: ON END MODULES, EAVE FITTINGS FOR BOTH EAVES AND RAFTERS ARE RIGID SLIP JOINTS.

HOOK THE END RAFTER TOP FITTING ONTO THE PEAK/RIDGE WELDMENT. THEN SLIDE THE END RAFTER ONTO THE BOTTOM OF THE END FITTING AND BOLT.

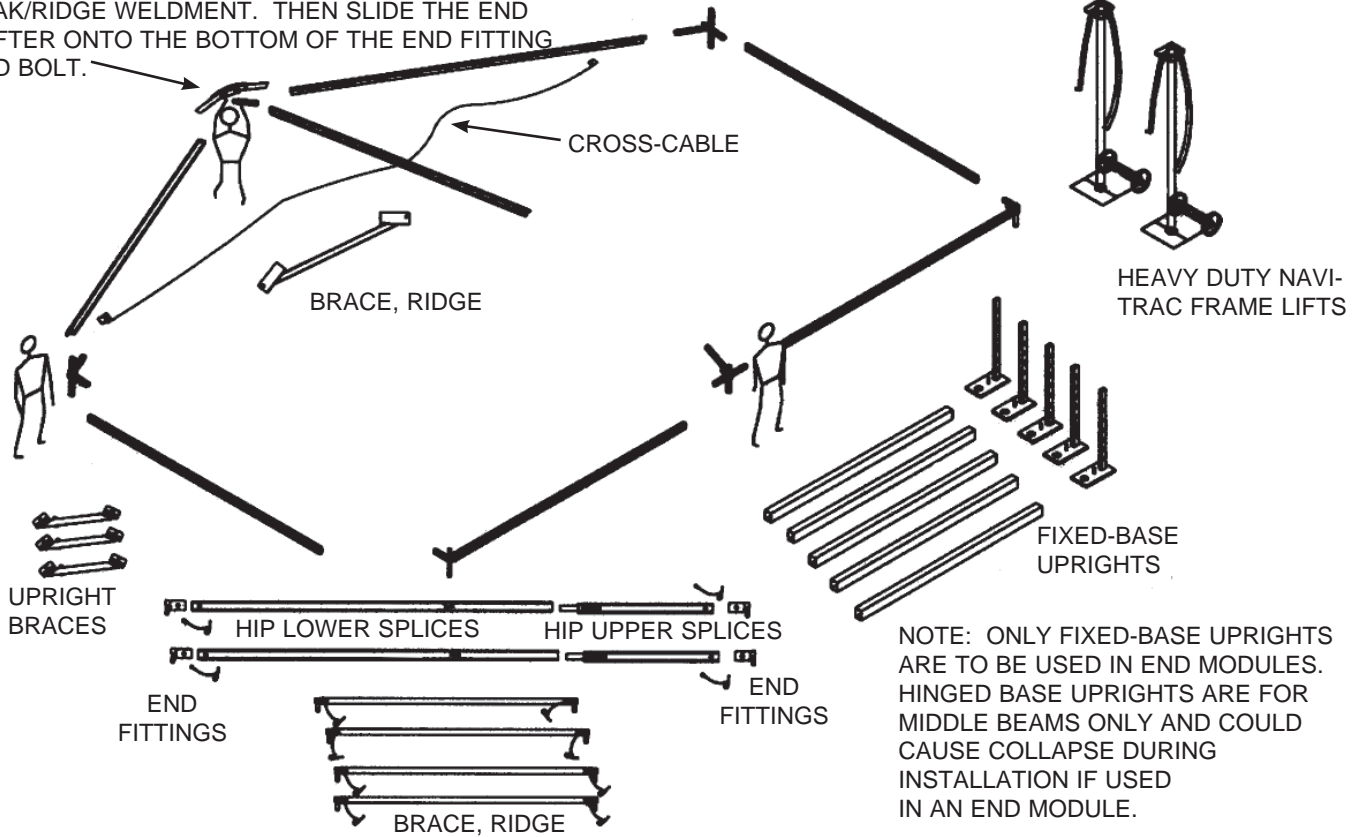

CONSTRUCT FIRST BEAM

FOR EASIEST ASSEMBLY, MAKE CONNECTIONS IN ORDER SHOWN

OPTION: IF YOU ARE ASSEMBLING A SQUARE UNIT, THE TRAILING END INTERMEDIATE RAFTER CAN BE ATTACHED TO THE PEAK NOW TO AVOID LATER CONNECTING IT FROM A LADDER.

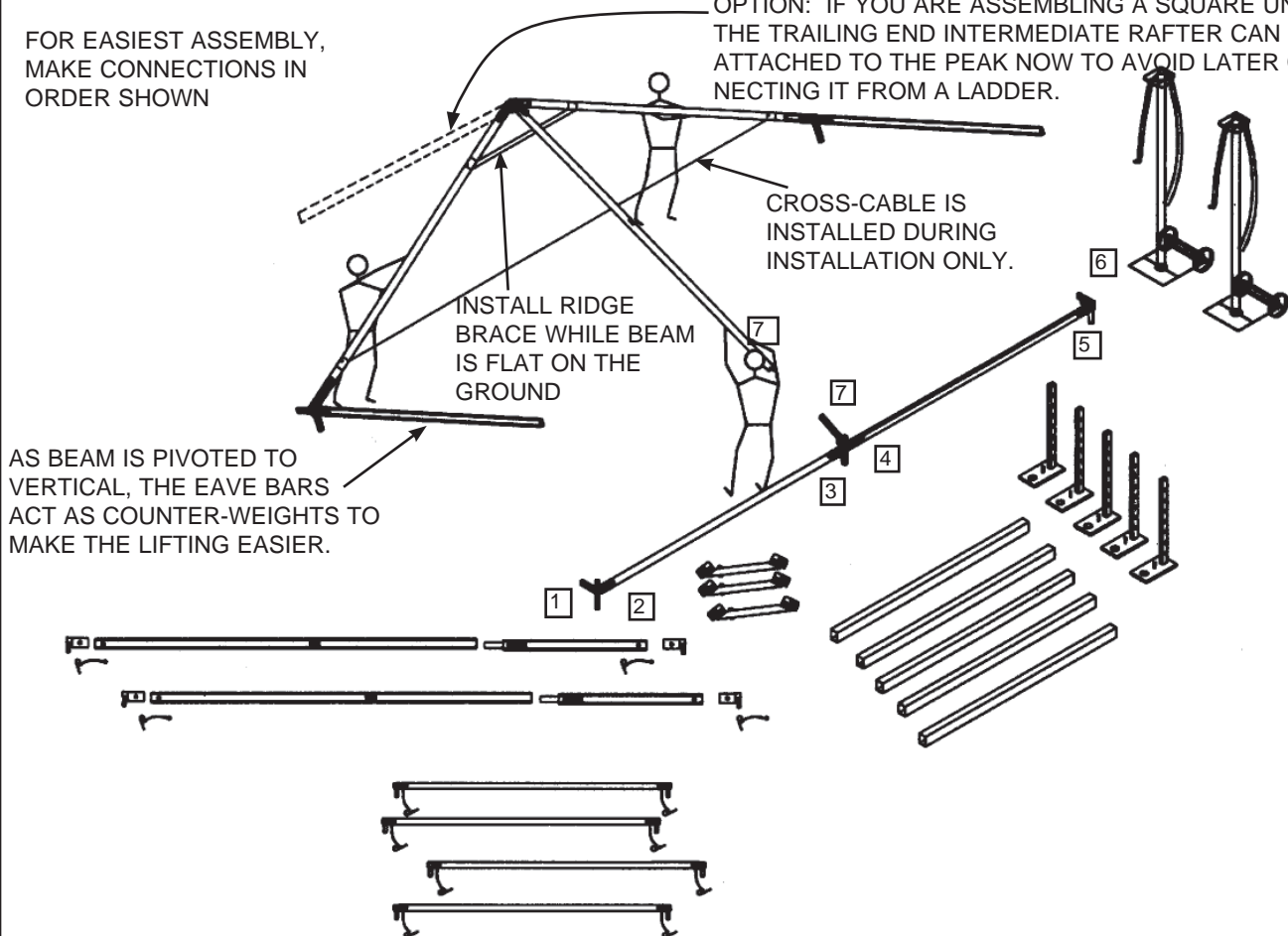

ASSEMBLING HIP END TOP FRAME

FOR MOST EASE, MAKE CONNECTIONS IN ORDER SHOWN.

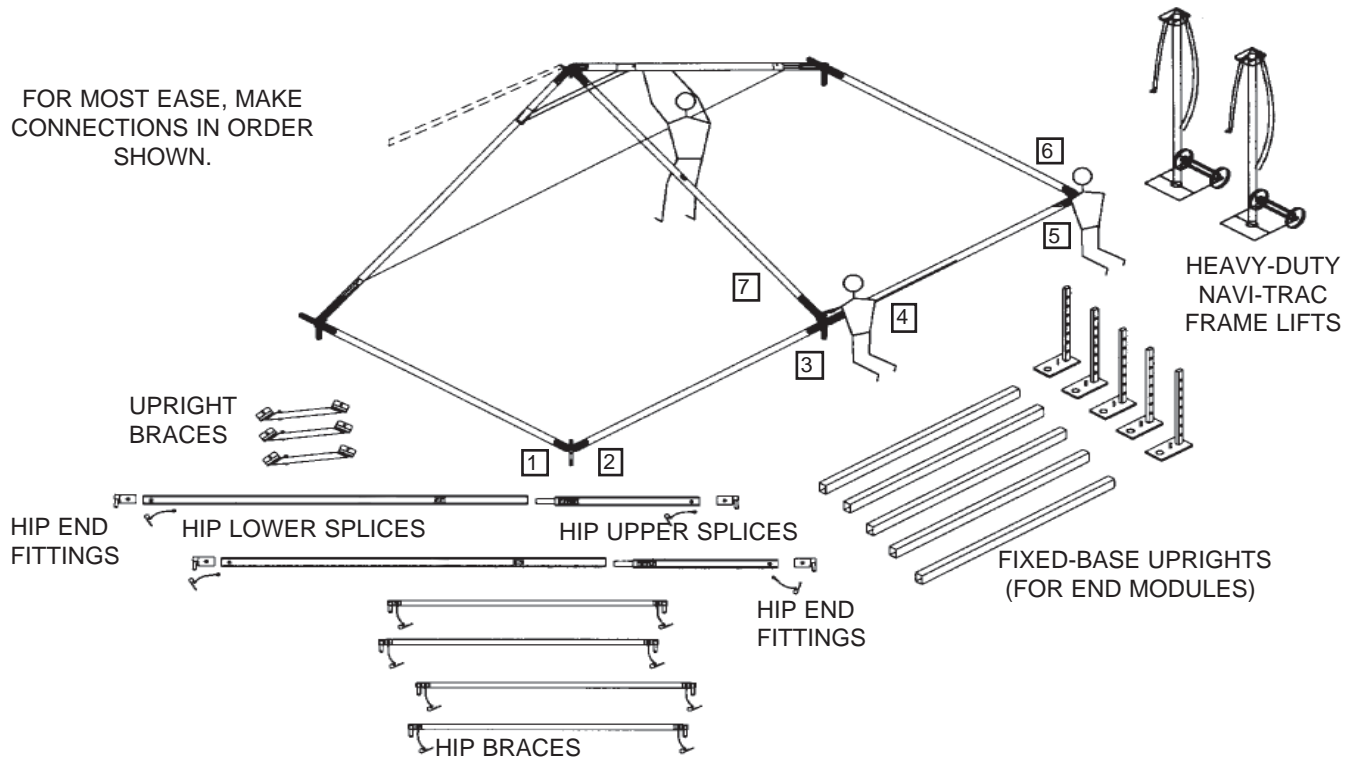

COMPLETING HIP END TOP FRAME

IF YOU ARE CONSTRUCTING AN EXTENDED RECTANGULAR TENT, INSTALL FABRIC NOW. IF YOU ARE CONSTRUCTING A SQUARE TENT, PROCEED TO THE NEXT STEP.

INSTALL DROP-IN HIPS AND HIP BRACES IN THE ORDER SHOWN. HINT: TO ALIGN HIP BRACES, LIFT CENTER OF HIP BAR, THEN DROP THE HIP BRACE CONNECTORS CLEANLY INTO FITTINGS.

USE LIFTING CRADLES TO MAKE HIP-PEAK CONNECTIONS. USE LADDER AS NEEDED TO SECURE PINS WITH LANYARDS

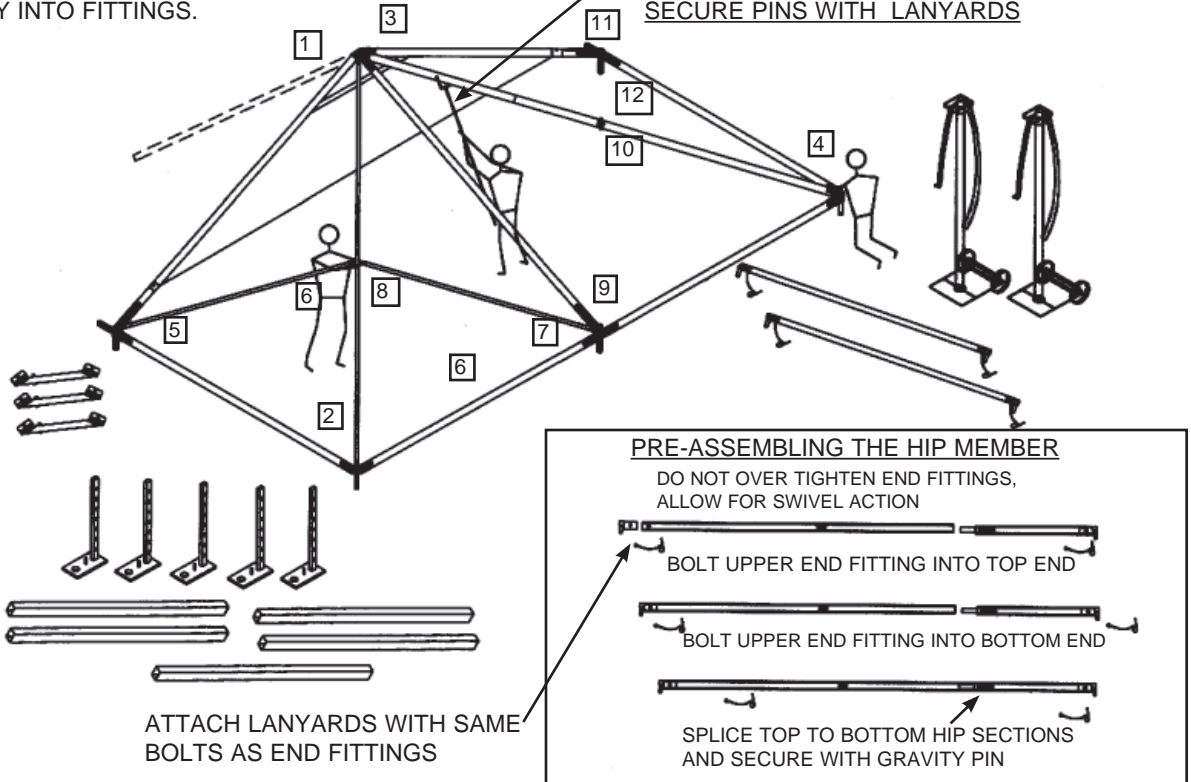

SUMMARY OF STEPS FOR COMPLETING THE SQUARE TENT

1. INSTALL OPPOSITE EAVES, RAFTERS, HIPS AND HIP BRACES TO COMPLETE SQUARE FRAME.
2. USE PULL ROPES TO PULL TOP FABRIC KEDAR FOR EACH END UP AND OVER THROUGH THE CHANNELS ON EACH SIDE OF THE RAFTERS THAT ARE ALIGNED WITH THE RIDGE BRACE.
3. LET FABRIC LAY LOOSELY ON TOP OF FRAME. SECURE WITH ROPES AS NEEDED AGAINST THE BREEZE.
4. USE HEAVY-DUTY NAVI-TRAC FRAME LIFTS TO LIFT FRAME ONE SIDE AT A TIME TO INSERT UPRIGHTS UNDER THE TOP FRAME.
5. INSTALL KNEE BRACES AT ALL INTERMEDIATE UPRIGHTS AS THEY ARE INSTALLED.
6. STAKE BASE PLATES USING STAKING LAYOUTS.
7. USE WEB/RATCHETS TO TENSION CATENARY FABRIC ARCHES TO UPRIGHT LEGS.
8. GUY TENT OUT AND STAKE. CONSULT STAKING LAYOUTS IN THIS MANUAL FOR HARD, VERY STIFF OR STIFF SOIL.

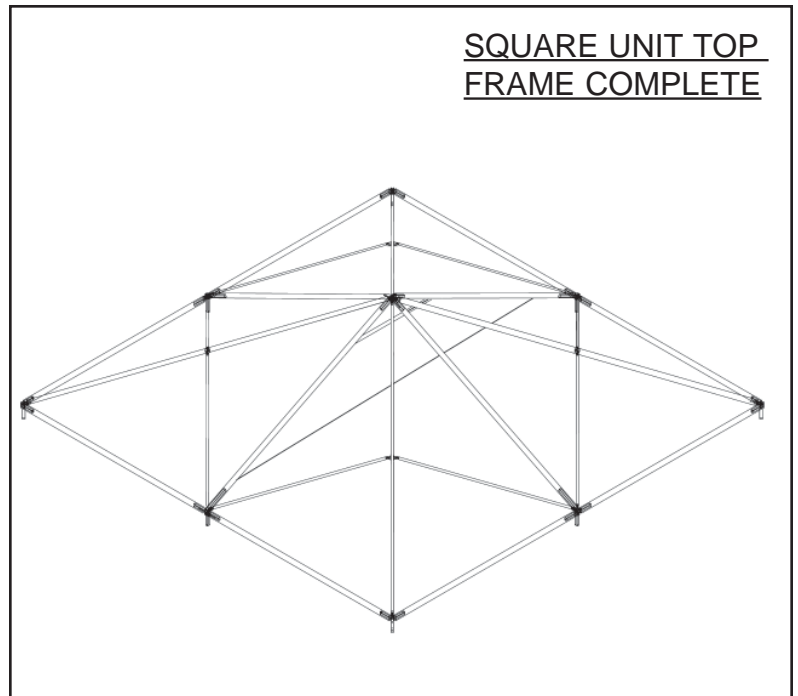

INSTALLING FABRIC ON HIP END FRAMES

NOTE: PULL ROPES MUST BE SNAPPED TO WEB PULL LOOP ON UNDERNEATH SIDE, JUST BELOW EAVE ON MIDS AND HIP ENDS. DO NOT ATTACH TO RINGS.

PULL FABRIC UP AND OVER THROUGH CHANNEL IN NAVI-TRAC RAFTER EXTRUSIONS. EACH HIP END IS ONE-PIECE. LET FABRIC TAILS HANG LOOSE UNTIL FRAME HAS BEEN LIFTED AND UPRIGHTS HAVE BEEN INSTALLED.

BE CAREFUL TO AVOID SNAGGING FABRIC ON OPEN ENDS OF END INTERMEDIATE RAFTERS HERE.

FABRIC STRAPS ON UNDERSIDE MUST CONNECT TO END INTERMEDIATE RAFTER

BE CAREFUL TO AVOID SNAGGING FABRIC ON OPEN ENDS OF END INTERMEDIATE RAFTERS HERE.

INSERT FINGERS OF WHEELED PANEL GUIDE INTO OPEN END OF RAFTER AND WELDMENT. TIGHTEN BUTTERFLY NUT. REVERSE FOR OPPOSITE SIDE OF BEAM.

RAFTER

WHEELED PANEL GUIDE

NOTE: BEFORE INSTALLING FABRIC, INSPECT THE FRAME TO ENSURE ALL HIP, AND BRACE PINS ARE PROPERLY SEATED AND SECURED WITH LANYARD PINS.

LIFTING TOP FRAME (FIRST SIDE)

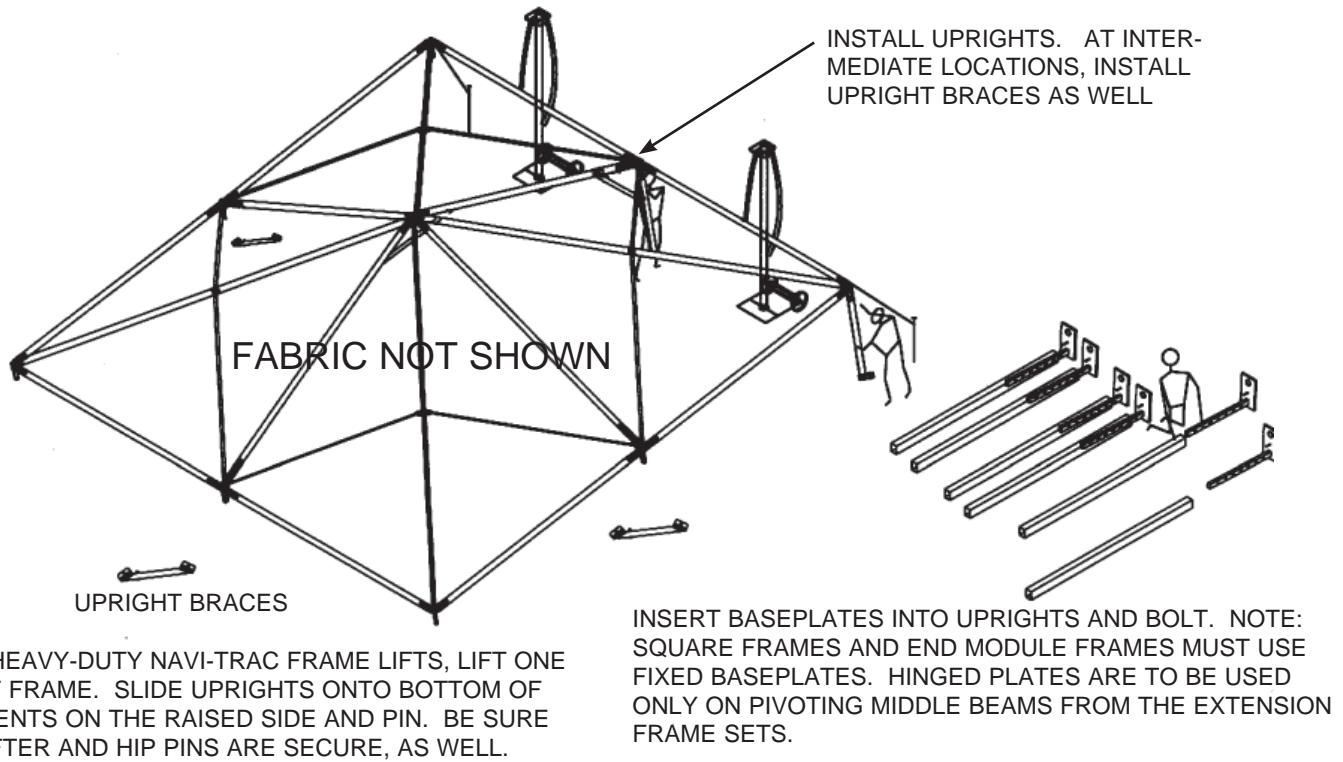

LIFT TOP FRAME (SECOND SIDE)

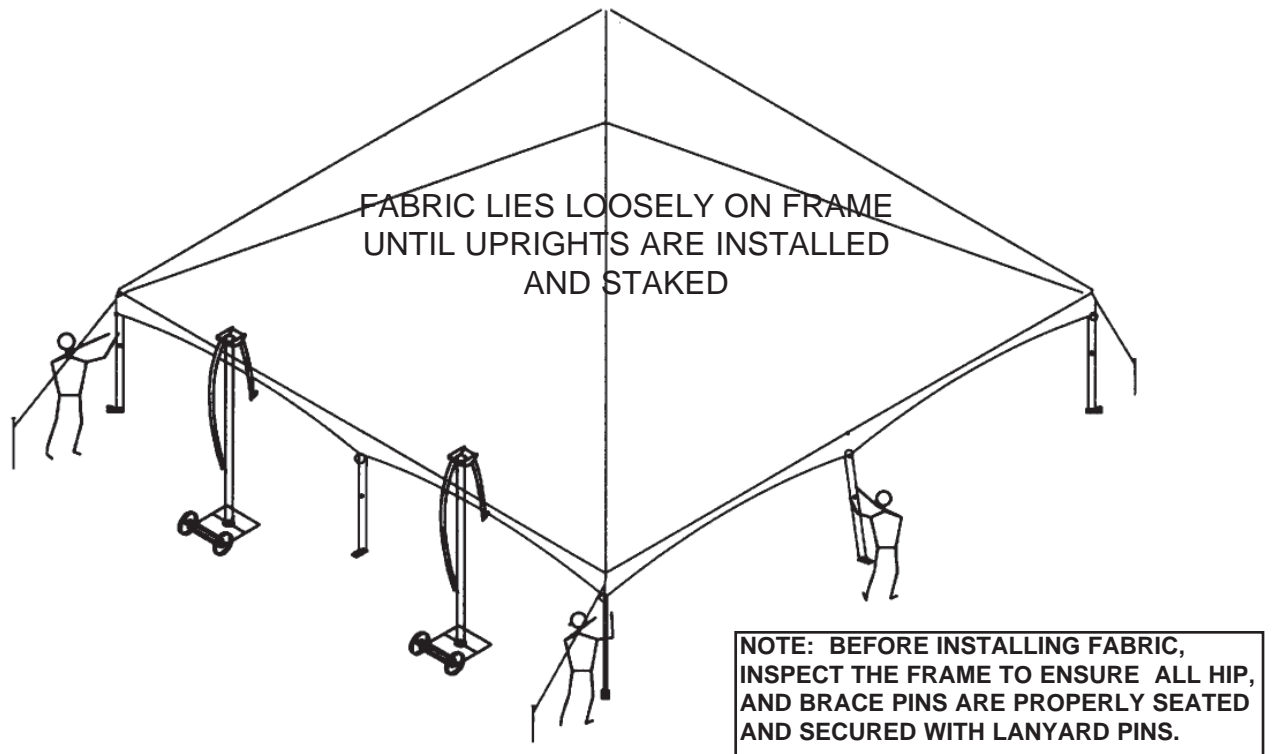

1. LIFT 2ND SIDE OF FRAME TO INSTALL OPPOSITE SIDE CORNER AND INTERMEDIATE UPRIGHTS.
2. INSTALL UPRIGHT BRACES AT ALL INTERMEDIATE UPRIGHTS.
3. WHEN BRACES ARE INSTALLED, THE CROSS-CABLE CAN BE REMOVED.

WEB GUY - STAKING GUIDELINES

REQUIRED DISTANCE OUT BETWEEN FRAME UPRIGHTS AND STAKE LINE IS EQUAL TO THE UPRIGHT HEIGHT.
(FOR EXAMPLE, 8' UPRIGHT = 8' STAKE-OUT DISTANCE.)

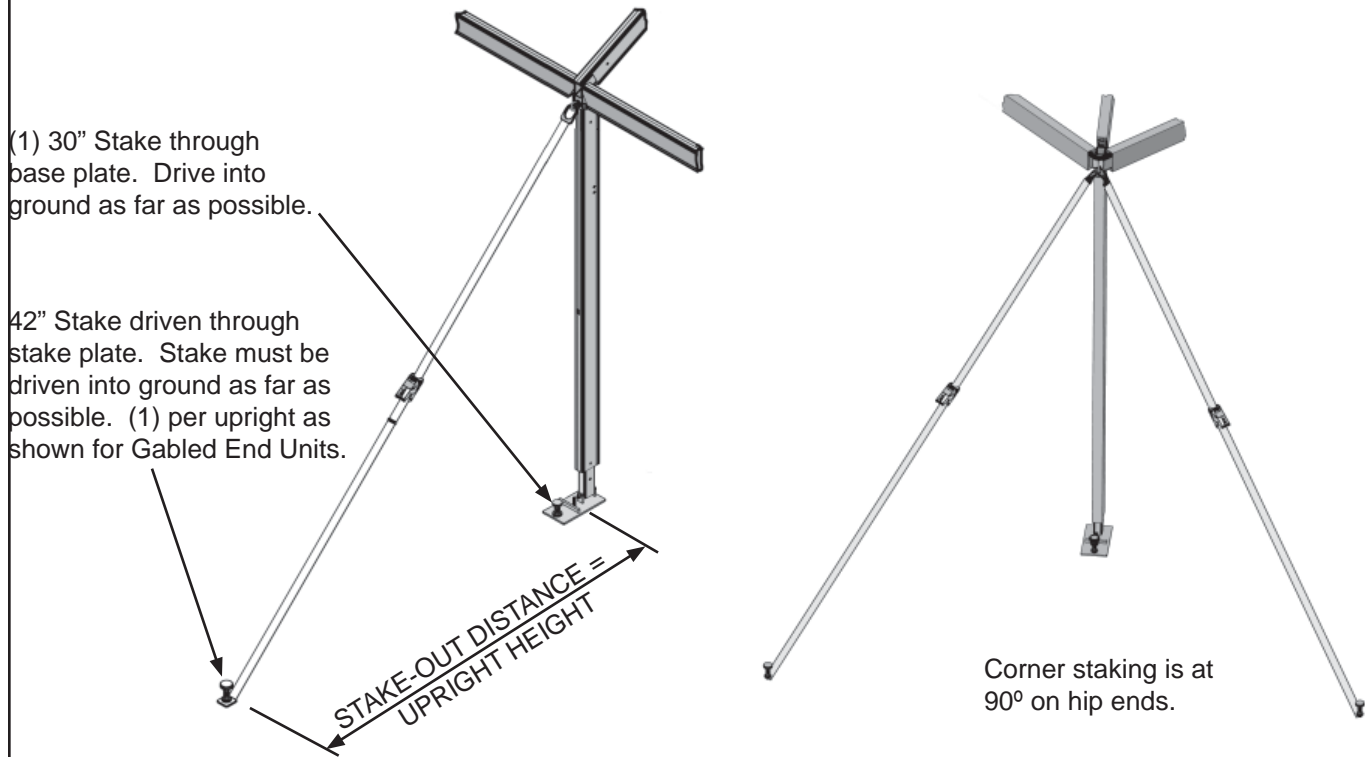

*** IMPORTANT NOTE:** REFER TO CAUTION STATEMENT #2 FOR IMPORTANT WARNING ABOUT NUMBER OF STAKES SUPPLIED. (SEE BACK PAGE OF THIS MANUAL)

THE INSTALLER MUST USE THE LOCAL SOIL CONDITIONS TO CALCULATE THE ACTUAL NUMBER OF STAKES REQUIRED AND IS RESPONSIBLE FOR THE STAKING PATTERN AND CONFIGURATION. ANCHOR PROVIDES ANCHORING PACKAGES FOR COMMON SOIL CLASSIFICATIONS; CONTACT YOUR TENT SALES REPRESENTATIVE FOR MORE INFORMATION.

TENSIONING AND GUYING

1. USE WEB/RATCHETS TO SECURE CATENARY ARCHES TO UPRIGHTS, STAKE BASEPLATES BEFORE TENSIONING WEBS.

2. ATTACH GUY WEBS TO EAVE WELDMENTS AND STAKE OUT AT A 45 DEGREE ANGLE (DISTANCE OUT = HEIGHT OF UPRIGHT, USUALLY 8 FT. USE 42" STAKES PROVIDED).

AT DOUBLE-GUYED CORNERS, GUYS FORM A 90 DEGREE ANGLE.

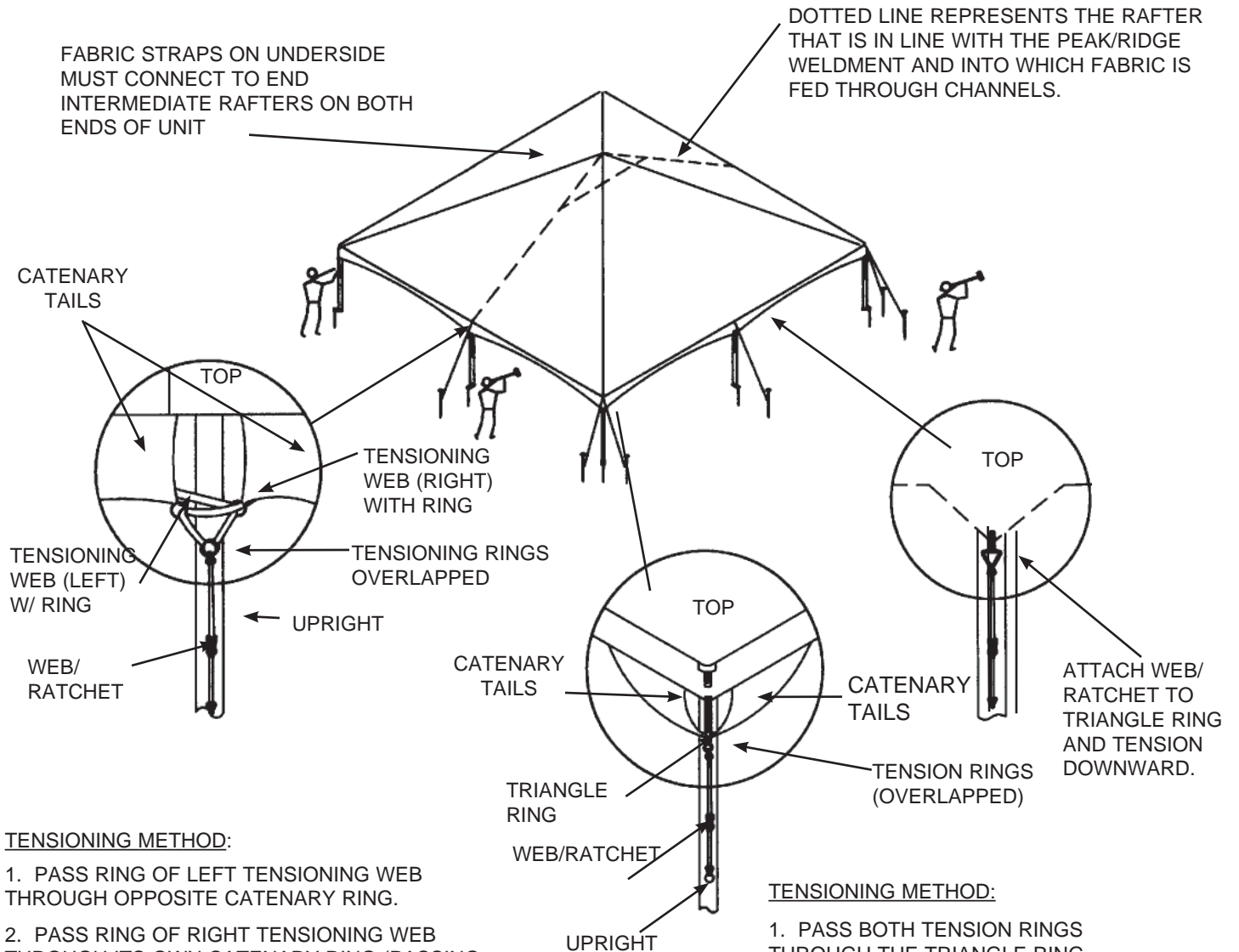

TENSIONING METHOD:

1. PASS RING OF LEFT TENSIONING WEB THROUGH OPPOSITE CATENARY RING.
2. PASS RING OF RIGHT TENSIONING WEB THROUGH ITS OWN CATENARY RING (PASSING OVER THE LEFT WEB).
3. CONTINUE RING OF RIGHT TENSIONING WEB THROUGH OPPOSITE CATENARY RING.
4. OVERLAP BOTH TENSION RINGS. ATTACH WEB/RATCHET AND TENSION DOWNWARD AGAINST TENSION HOLE IN UPRIGHT. (CATENARY RINGS SHOULD MOVE CLOSER TOGETHER AS RATCHET IS TIGHTENED.)
5. TENSION WITH WEB/RATCHETS UNTIL CATENARY ARCHES ARE EQUIDISTANT BELOW BOTTOMS OF EAVE BARS.

TENSIONING METHOD:

1. PASS BOTH TENSION RINGS THROUGH THE TRIANGLE RING.
2. OVERLAP THEM AND ATTACH WEB/RATCHET TO TENSION DOWNWARD.

HIP END MODULES FOR RECTANGULAR UNITS

THE RECTANGULAR UNIT IS SIMPLY (2) HIP ENDS FACING EACH OTHER AND SEPARATED BY PARALLEL-BEAMED MIDDLE BAYS.

LIFT FIRST SIDE AND INSTALL UPRIGHTS (WITH UPRIGHT BRACES AT INTERMEDIATE LOCATIONS).

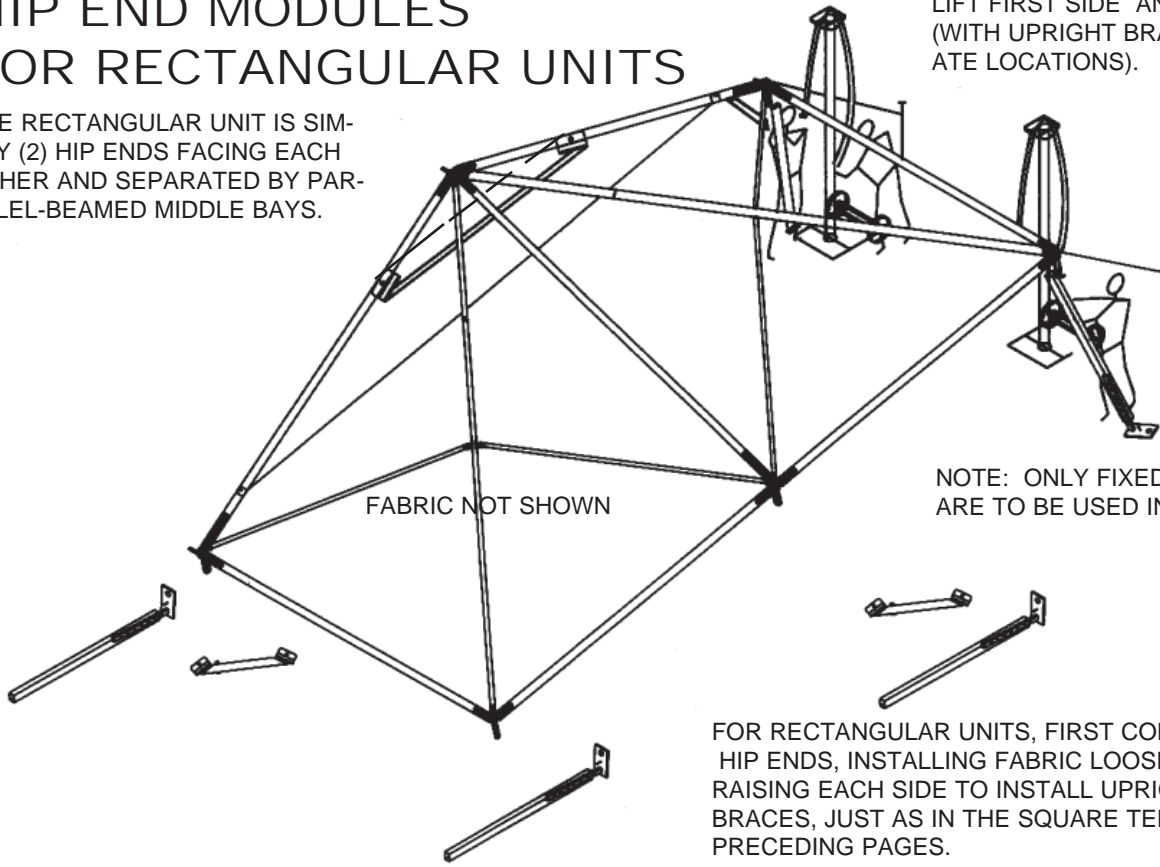

NOTE: ONLY FIXED-BASE UPRIGHTS ARE TO BE USED IN END MODULES.

FOR RECTANGULAR UNITS, FIRST CONSTRUCT HIP ENDS, INSTALLING FABRIC LOOSELY AND RAISING EACH SIDE TO INSTALL UPRIGHTS AND BRACES, JUST AS IN THE SQUARE TENT IN PRECEDING PAGES.

COMPLETING THE HIP END

LIFT SECOND (OPPOSITE) SIDE OF HIP END AND PIN UPRIGHTS INTO POSITION. INSTALL UPRIGHT BRACES AT INTERMEDIATE POSITIONS. AFTER UPRIGHT BRACES ARE INSTALLED, CROSS-CABLE CAN BE REMOVED

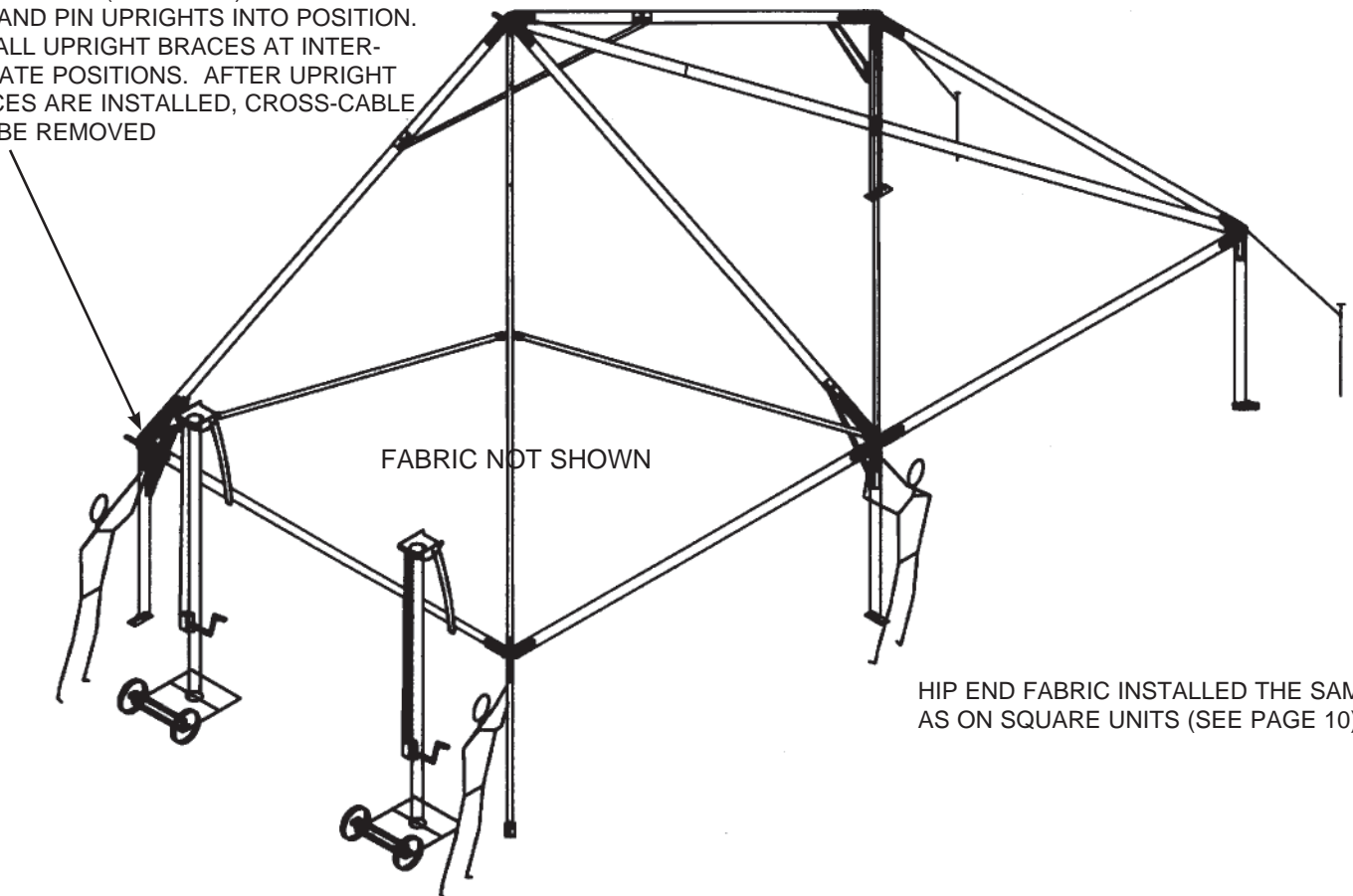

HIP END FABRIC INSTALLED THE SAME AS ON SQUARE UNITS (SEE PAGE 10)

UNITS WITH (1) MIDDLE BAY

(2) END MODULES FACING EACH OTHER.

NOTE: FABRIC ONLY INDICATED, SO THAT FRAME WILL BE MORE VISIBLE.

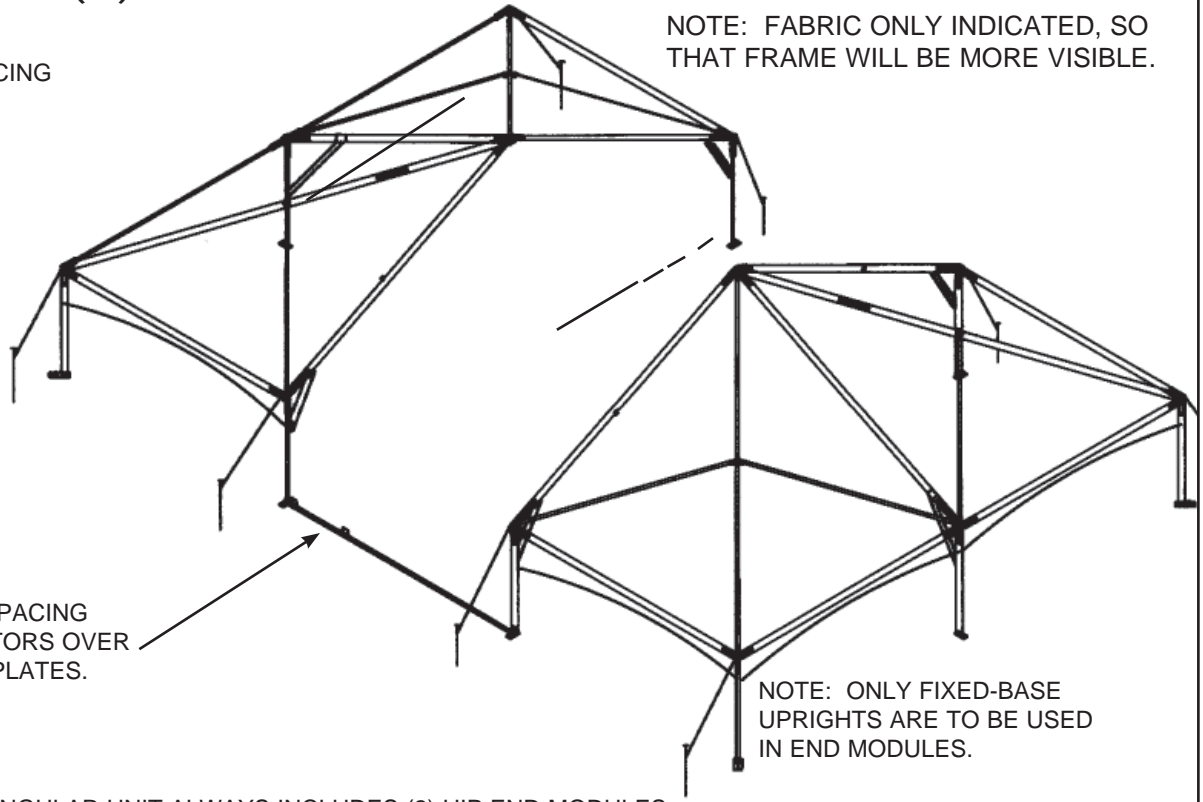

ADJUST TO DESIRED SPACING AND FIT END CONNECTORS OVER GUIDE PEGS ON BASEPLATES.

NOTE: ONLY FIXED-BASE UPRIGHTS ARE TO BE USED IN END MODULES.

THE EXTENDED RECTANGULAR UNIT ALWAYS INCLUDES (2) HIP END MODULES FACING EACH OTHER WITH THE DESIRED NUMBER OF 10', 15' OR 20' MIDDLE BAYS SEPARATING THEM. NOTE: UNLIKE THE RIGID EAVE AND LOWER RAFTER CONNECTIONS OF THE END MODULE, MIDDLE BAYS USE DROP-IN PURLINS AND EAVE/RIDGE BARS.

INSTALLING MID BAY PURLINS AND EAVE/RIDGE BARS

CONNECTION SEQUENCE MAY CHANGE WITH THE TERRAIN

NOTE: FABRIC ONLY INDICATED, SO THAT FRAME WILL BE MORE VISIBLE.

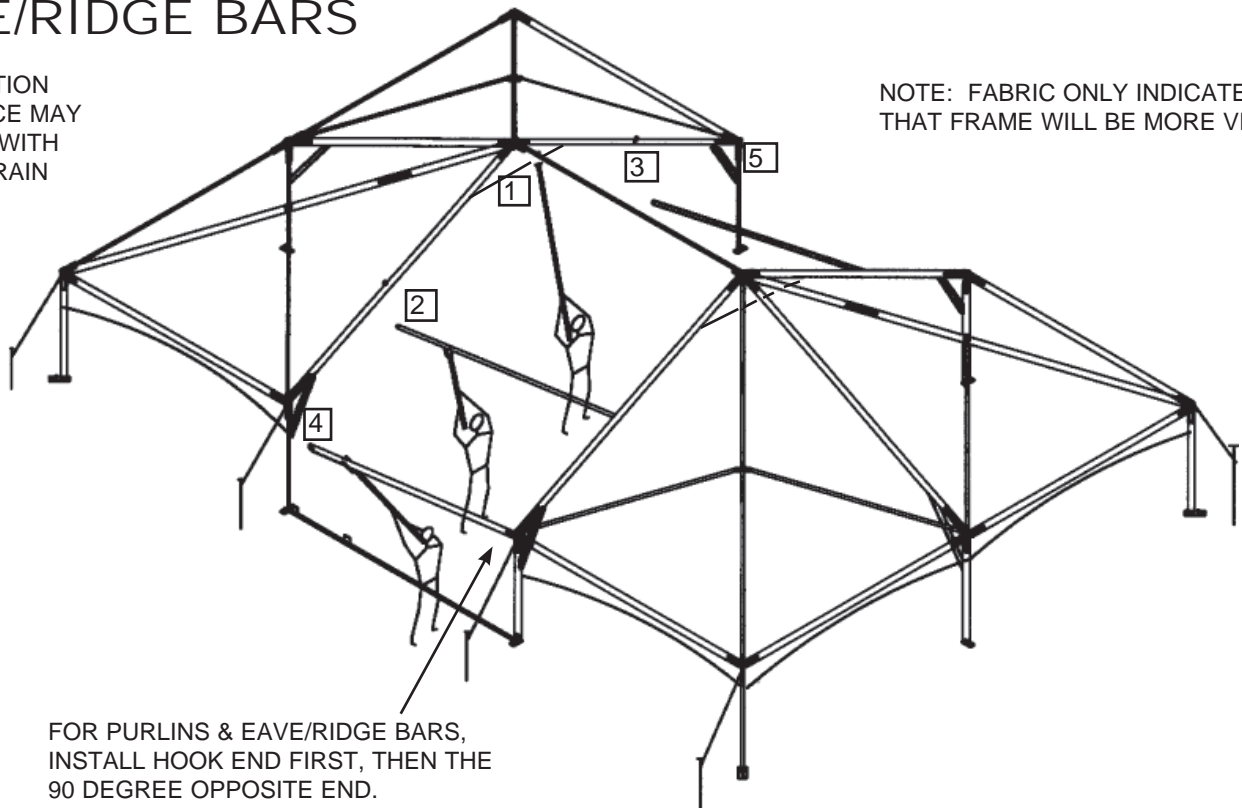

FOR PURLINS & EAVE/RIDGE BARS, INSTALL HOOK END FIRST, THEN THE 90 DEGREE OPPOSITE END.

PURLIN SUPPORTS IN 20' MID BAYS

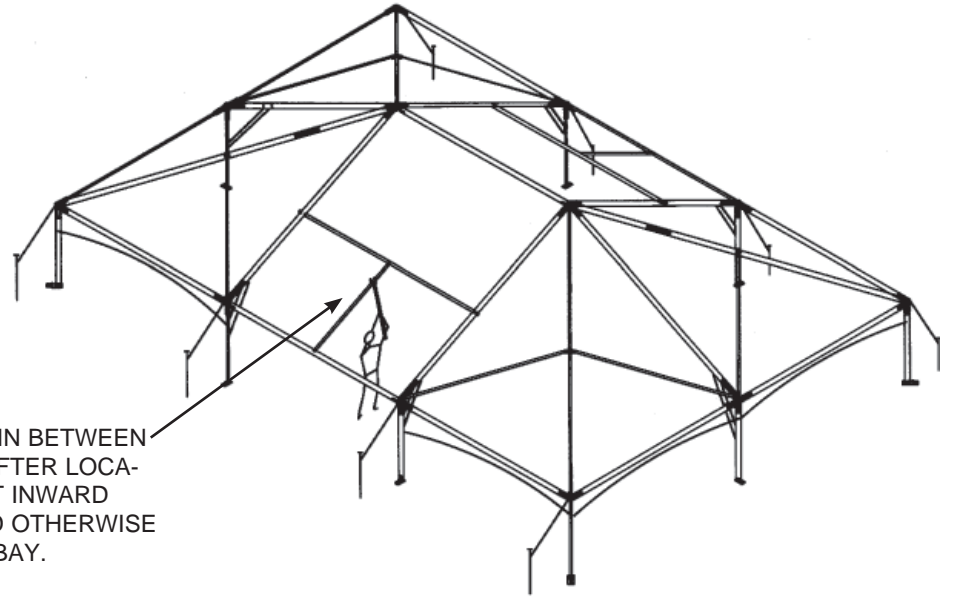

IN 20' MID BAYS, INSTALL A SUPPORT PURLIN BETWEEN THE EAVE AND THE PURLIN AT THE MID-RAFTER LOCATION. THIS SUPPORT WILL BRACE AGAINST INWARD DEFLECTION OF THE EAVE BAY THAT COULD OTHERWISE RESULT IN WATER PONDING IN THE 20 FT. BAY.

INSTALLING MID PANEL

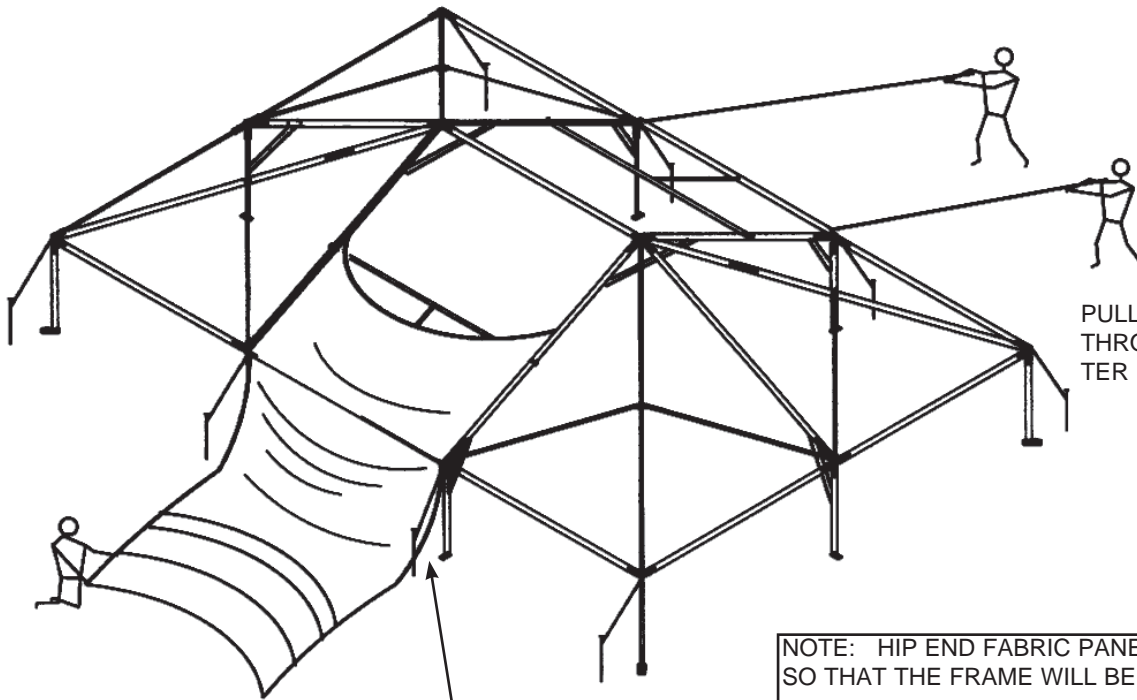

PULL MID PANEL UP AND OVER THROUGH CHANNELS IN RAFTER EXTRUSIONS.

NOTE: HIP END FABRIC PANELS NOT SHOWN SO THAT THE FRAME WILL BE MORE VISIBLE.

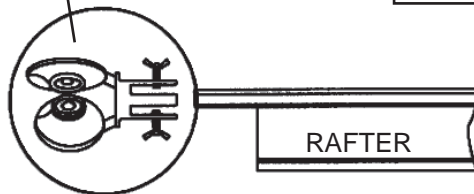

WHEELED
PANEL
GUIDE

INSERT FINGERS OF WHEELED PANEL GUIDE INTO THE OPEN END OF THE RAFTER AND WELDMENT. TIGHTEN THE BUTTERFLY NUT. REVERSE FOR OPPOSITE SIDE OF BAY.

UNITS WITH (2) OR MORE MID BAYS

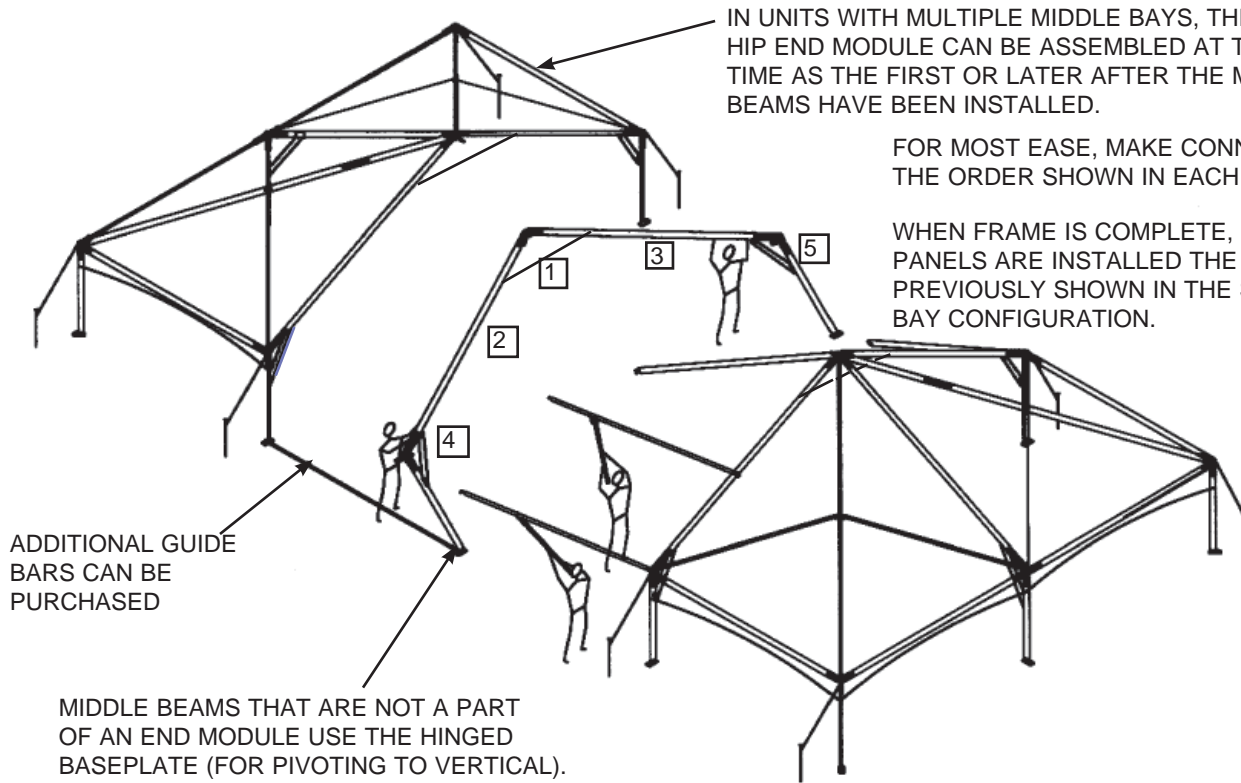

IN UNITS WITH MULTIPLE MIDDLE BAYS, THE SECOND HIP END MODULE CAN BE ASSEMBLED AT THE SAME TIME AS THE FIRST OR LATER AFTER THE MIDDLE BEAMS HAVE BEEN INSTALLED.

FOR MOST EASE, MAKE CONNECTIONS IN THE ORDER SHOWN IN EACH BAY.

WHEN FRAME IS COMPLETE, MID PANELS ARE INSTALLED THE SAME AS PREVIOUSLY SHOWN IN THE SINGLE MID BAY CONFIGURATION.

ADDITIONAL GUIDE BARS CAN BE PURCHASED

MIDDLE BEAMS THAT ARE NOT A PART OF AN END MODULE USE THE HINGED BASEPLATE (FOR PIVOTING TO VERTICAL).

FIXED PLATES ARE STAMPED "END" AND SHOULD BE USED ONLY ON END MODULES.

X-CABLED BAYS

FOR CABLE CONNECTIONS AT MID PORTION OF RAFTERS, INSERT THE BOLTS IN THE HOLES OF THE RAFTER THAT ARE JUST ABOVE AND JUST BELOW THE PURLIN CONNECTION. THREADS SHOULD POINT INWARD TOWARD EACH OTHER. THREAD CABLE EYE NUTS ONTO EACH BOLT TO SECURE THE CABLES AS SHOWN.

UPPER RAFTER X-CABLES ARE COLOR-CODED BLUE AND LABELED 10, 15, OR 20 ACCORDING TO BAY SIZE.

LOWER RAFTER X-CABLES ARE COLOR-CODED RED AND LABELED 10, 15, OR 20 ACCORDING TO BAY SIZE.

UPRIGHT X-CABLES ARE COLOR-CODED GREEN AND LABELED 10, 15, OR 20 ACCORDING TO BAY SIZE.

STAKE PLATES AT PROPER SPACING BEFORE INSTALLING THE X-CABLES. THEN, ADJUST TURNBUCKLES UNTIL CABLE IS SNUG

NAVI-TRAC UNITS 100 FT. OR MORE IN LENGTH MUST HAVE AN X-CABLED BAY NEAR THE MIDDLE OF THE UNIT (AND/OR EQUALLY SPACED) FOR EVERY 100 FT. UNIT OF LENGTH.

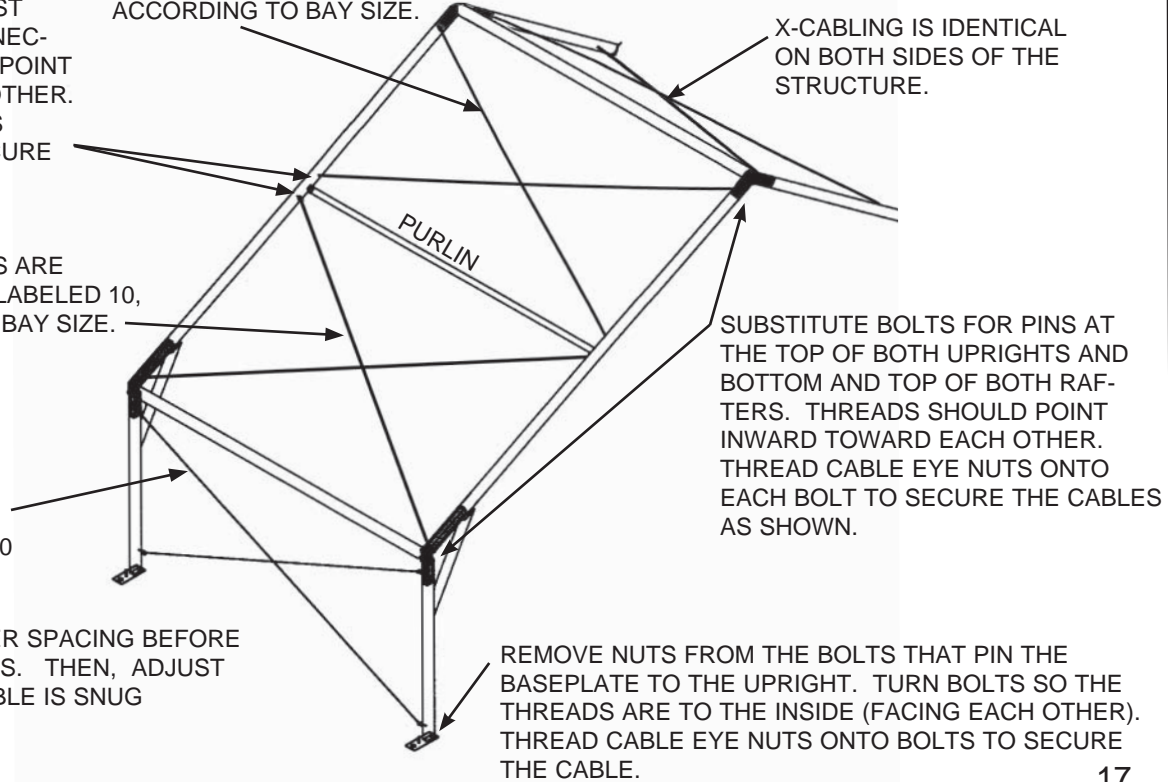

X-CABLING IS IDENTICAL ON BOTH SIDES OF THE STRUCTURE.

SUBSTITUTE BOLTS FOR PINS AT THE TOP OF BOTH UPRIGHTS AND BOTTOM AND TOP OF BOTH RAFTERS. THREADS SHOULD POINT INWARD TOWARD EACH OTHER. THREAD CABLE EYE NUTS ONTO EACH BOLT TO SECURE THE CABLES AS SHOWN.

REMOVE NUTS FROM THE BOLTS THAT PIN THE BASEPLATE TO THE UPRIGHT. TURN BOLTS SO THE THREADS ARE TO THE INSIDE (FACING EACH OTHER). THREAD CABLE EYE NUTS ONTO BOLTS TO SECURE THE CABLE.

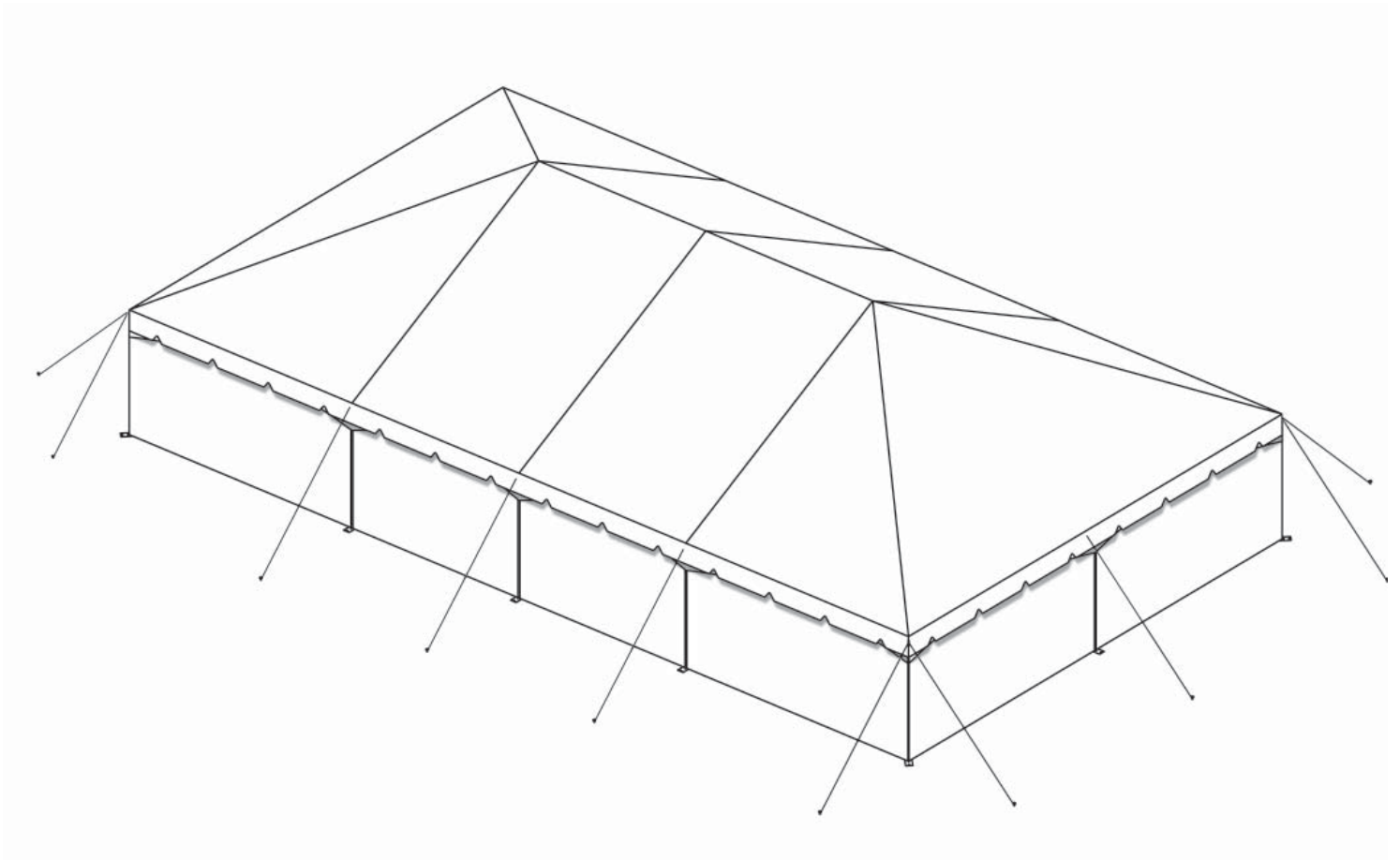

40' NAVI-TRAC COMPLETE WITH (2) 15' MID BAYS

1. ALL ENGINEERING ON THE 40' NAVI-TRAC WAS DONE WITH THE WALLS IN PLACE. (FULLY ENCLOSED). SEE NEXT PAGE FOR SIDEWALL INSTALLATION.
2. INSTALL, STAKE, AND TENSION ALL GUY WEBS, AS SHOWN. TENSION FABRIC SO THAT ALL CATENARY ARCHES ARE EQUIDISTANT BELOW THE EAVE BARS.
3. REVIEW PAGE 12 FOR GUYING AND TENSIONING INSTRUCTIONS.

Wall Installation

Step 1

Determine which side of wall is inside and out. Ground bar pockets are on outside, Lace flap is on inside. Start by feeding top of kedar edge into channel opening until top of wall is as far as it will go. (Figure A)

Insert the bottom edge of kedar into channel opening and feed down until wall is smoothly installed into upright.

Step 2

Starting with wall tab nearest the lace, insert into slotted opening in bottom channel of eave bar. Feed rest of wall tabs into channel.

Step 3

Repeat with the matching half of the wall.

Step 4

Lace wall starting at top of wall bringing top loop thru the top grommet of matching half of wall to inside of wall. Continue with this process looping next loop thru grommet and then the upper loop until all loops are laced. (See Figure B) Tie off bottom loop to keep lace together.

Step 5

Slide ground bar (Figure C) thru pocket on outside of wall. Fasten to frame using the ground bar keeper as noted on next page.

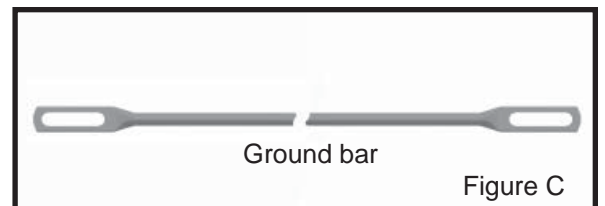
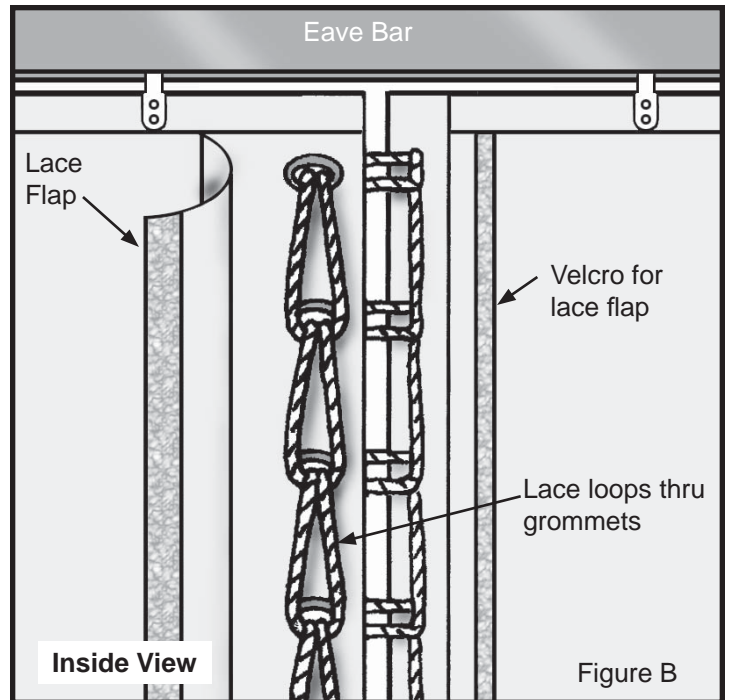
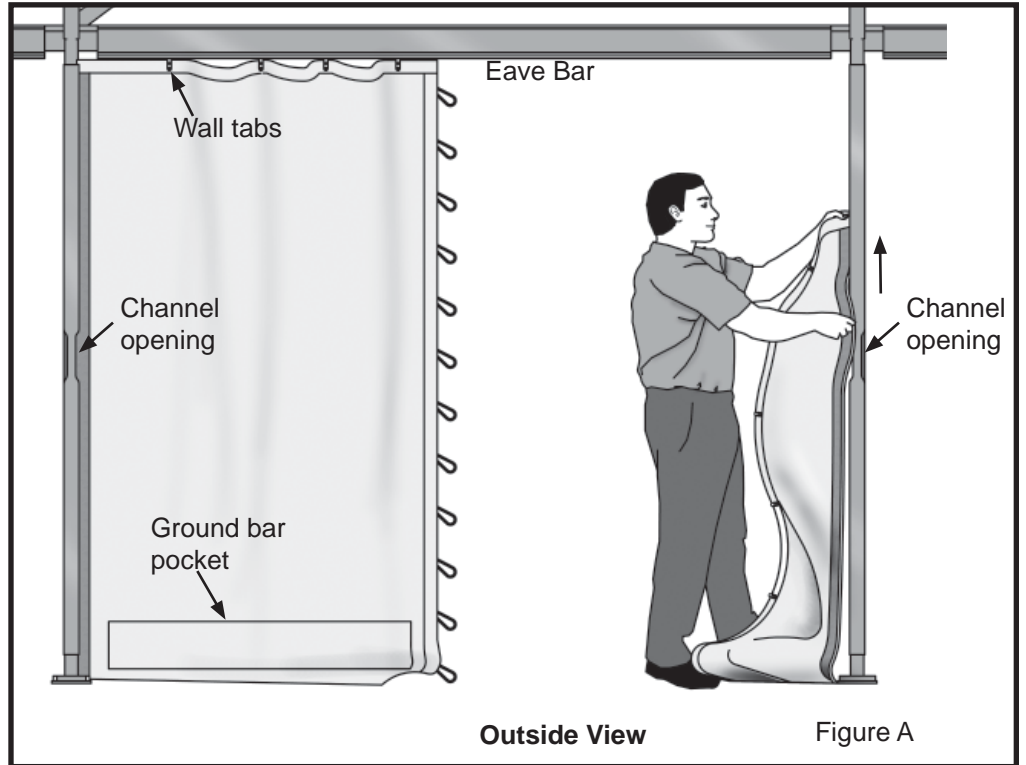

Navi-Trac Ground Bar Keeper Instructions

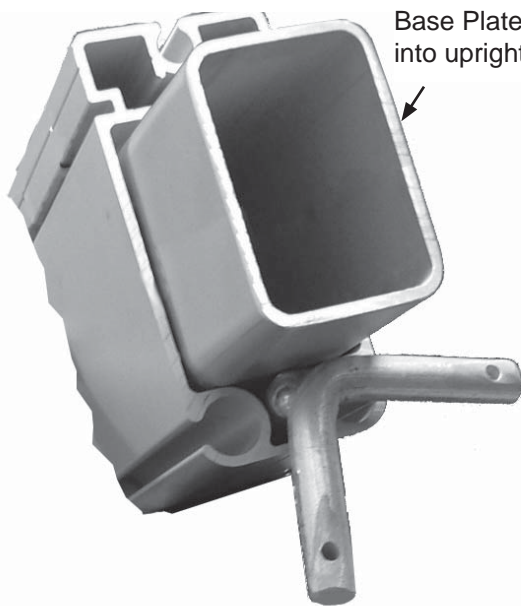
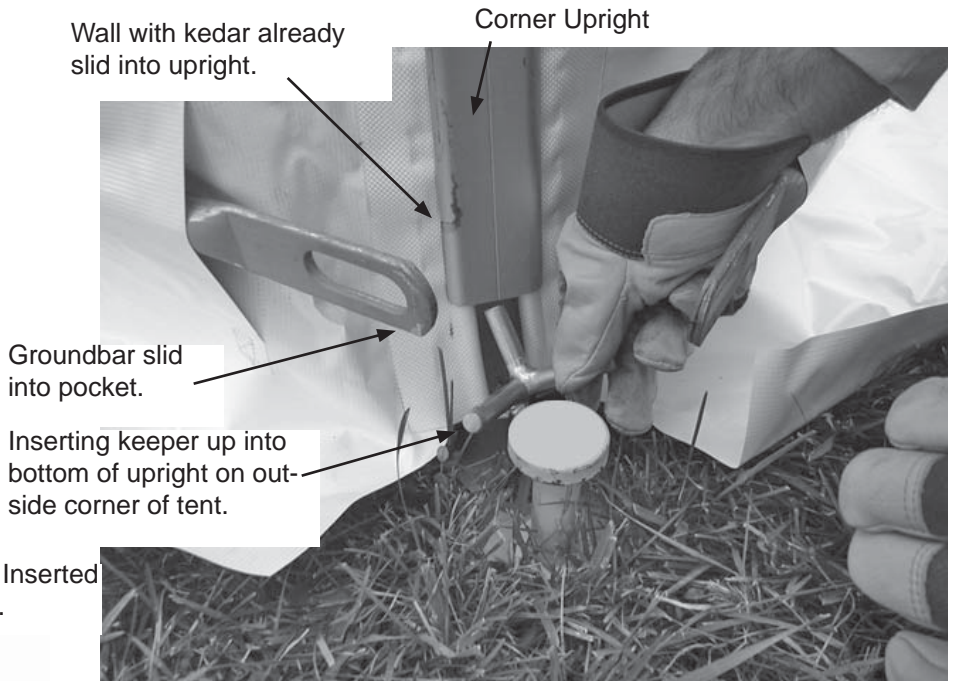
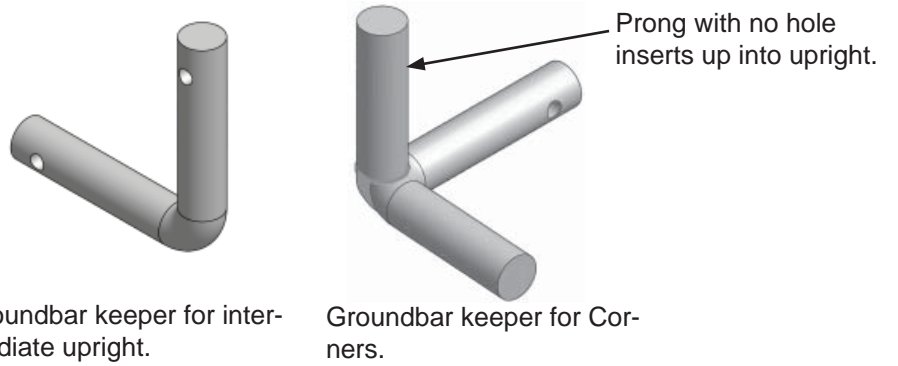
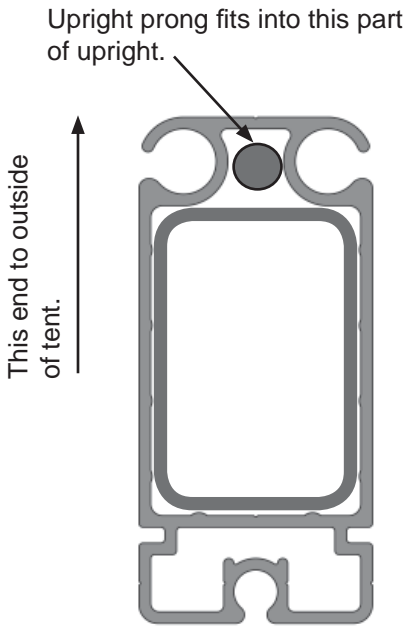

Bottom View looking up into upright with Groundbar keeper inserted.



PHONE NUMBER
812- 867- 2421

FAX NUMBER
812- 867- 0547

Anchor products are of superior design and operate best within the parameters of these instructions. It is imperative that the instructions be carefully read and **COMPLETELY FOLLOWED**. Please read installation instructions before the installation or removal of this product. Installation instructions are available online at www.anchorinc.com or by calling 1-800-544-4445.

CAUTION:

1. For each installation, the installer is solely responsible for evaluating the site and the proper securing method determined. Some soils require different staking or securing than that provided with the tent. Due to this variety of soil conditions, these are the manufacturer's suggested sequence of installation procedures. Anchor's responsibility is limited to the manufacture of the tent parts and materials. We are not responsible for methods that installers may choose to erect and secure the tent to the ground.
2. The number of stakes suggested in the installation instructions do not necessarily meet all or any relevant codes on the site of the tent installation. The number of stakes suggested **will, in many cases, keep the tent erected**, however, due to various soil conditions; these stakes will be insufficient **to keep the tent secure in high winds**. It is the tent installer's responsibility, not the manufacturer, to determine the appropriate number of stakes to meet the necessary wind loads on the site. Regardless of the number of stakes we suggest, we make no representation or warranty as to whether this specific number of stakes will meet the local tent code. Anchor does not, nor can it make any suggestions, representation, or warranties about the adequate staking required at each specific installation site. Staking information provided in the installation instructions **is not a suggestion about what is necessary to meet a site-specific load**.

For additional important information, consult: "The IFAI Procedural Handbook For the Safe Installation and Maintenance of Tentage" and the IFAI Pocket Guide "Pullout Capacity of Tent Stakes", both available from the IFAI Tent Rental Division or on our website.

3. Inasmuch as the weather is unpredictable, good judgment and common sense must be incorporated within installation guidelines. It is the responsibility of the tent installer/maintainer to determine the severity of the weather, proper time and method of installation and/or erection and disassembly. **Note: We recommend that snow and ice be removed from the tent surface as soon as possible because accumulation will damage the tent or fabric structure. Please consult with our Engineering Department about the maximum loads for each product.**

This product has been manufactured to meet code requirements. For the safety of all occupants, evacuation is recommended if threatening weather occurs, or if there is any doubt concerning the safe use of this product.

4. Proper safety equipment should be used at all times to insure a safe installation and take down. We suggest a careful evaluation be made to determine safety equipment needed, such as hard hats, steel-toe shoes, safety glasses and other as required. It is our desire that all installations are safe. Please be aware of hidden dangers both underground, i.e., gas lines, water lines, electrical lines, etc. and above the tent such as power lines and telephone lines.
5. Anchor stands behind its products in accordance with its standard Terms and Conditions of sale. A copy of our Terms and Conditions of Sale can be obtained by contacting Anchor at the telephone number and/or address on this document.