

Assembly Instructions

Navi-Trac® Frame Tent

40' Wide Gable End System

Please read all assembly / installation instructions before the installation or removal of this product.

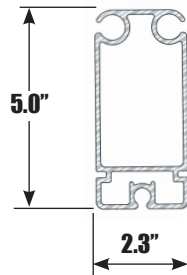
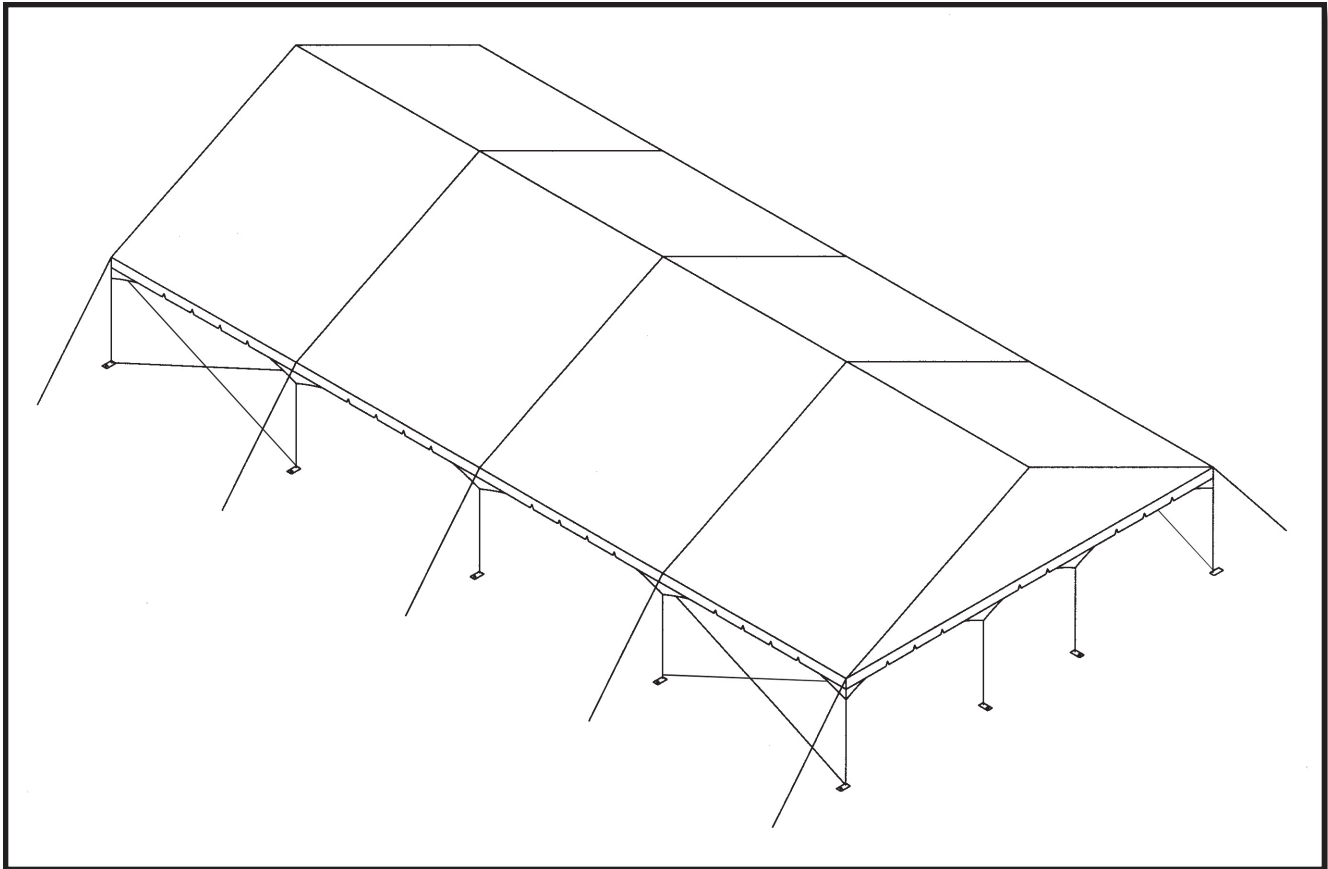

1100 Burch Dr., Evansville, IN 47725
Ph. 812-867-2421 • Fax. 812-867-0547
E-mail: tents@anchorinc.com • www.anchorinc.com

Table of Contents

Page No.	Assembly Step
3	Introduction Inspect Site Frame Terminology
4	Component Illustrations
5	40' Navi-Trac Component List Table
6	40' Navi-Trac Component List Table Cont'd
7	Safety Guidelines
8	Squaring the Tent - Footprint Layout
9	Web Guy - Staking Guidelines Assembling the first Beam
10	Layout of all Beams Erecting second Beam first
11	Connecting the First Two Beams
12	Installing Purlins Completing First Bay Completing the Top Frame Installing the Gabled End Frame
13	Installing Guy Webs X-Cabled Bays
14	Installing Mid Panels Installing Gabled End Panels
15	Fabric Tensioning
16	Completed Gabled End Unit Illustration Alternate Hip End/ Gabled End Configuration
17	Combining Hip and Gabled End Assembly Steps Component Changes for Hip/ Gabled End Configuration
18	Diagonal Beam Brace
19	Wall Installation
20	Ground Bar Keeper
21	Limits of Liability

INTRODUCTION:

Like the hip-end version, the gabled end NAVI-TRAC frame is made up of extruded aluminum members joined by weldments. The aluminum frame members themselves are extruded with channels into which the NAVI-TRAC fabric “kedar” is fed. However, the gabled end version of the Navi-Trac differs from the Hip End version in a number of ways:

1. All the beams are parallel to each other.
2. Beam base plates are hinged for pivoting to a vertical position. End Upright plates are fixed, non-pivoting.
3. The eave fittings are the MCW style that allows a simple drop-in action for purlin installation, rather than the slip joint of the hip end configuration.
4. Fabric middle bays are installed into the channels of adjacent beams one bay at a time.
5. Gabled End fabric is installed simply into the outer channel of the end beams and tensioned to the Gabled End uprights.
6. X- cabling extends into the overhead rafter area to compensate for the lack of hip end support.
7. Corner guys are in one direction only, parallel to the beams.

Note: It is possible to combine the hip end and gabled end styles within one building unit (see kit #3); however, this assembly manual focuses on the gabled end configuration only. The last few pages describe the hip/gabled combination and refer the customer to the hip end assembly manual for the hip end part of the building unit.

INSPECT SITE

CAUTION:

Consult your local [utility locator service](#) or the [National Utility Locating Contractors Association \(NULCA\)](#) prior to installation.

Prior to actual tent assembly, be sure to look up, down, above & below for obstacles, pipes, wires, trouble, etc.

40' Gabled Navi-Trac Frame Terminology

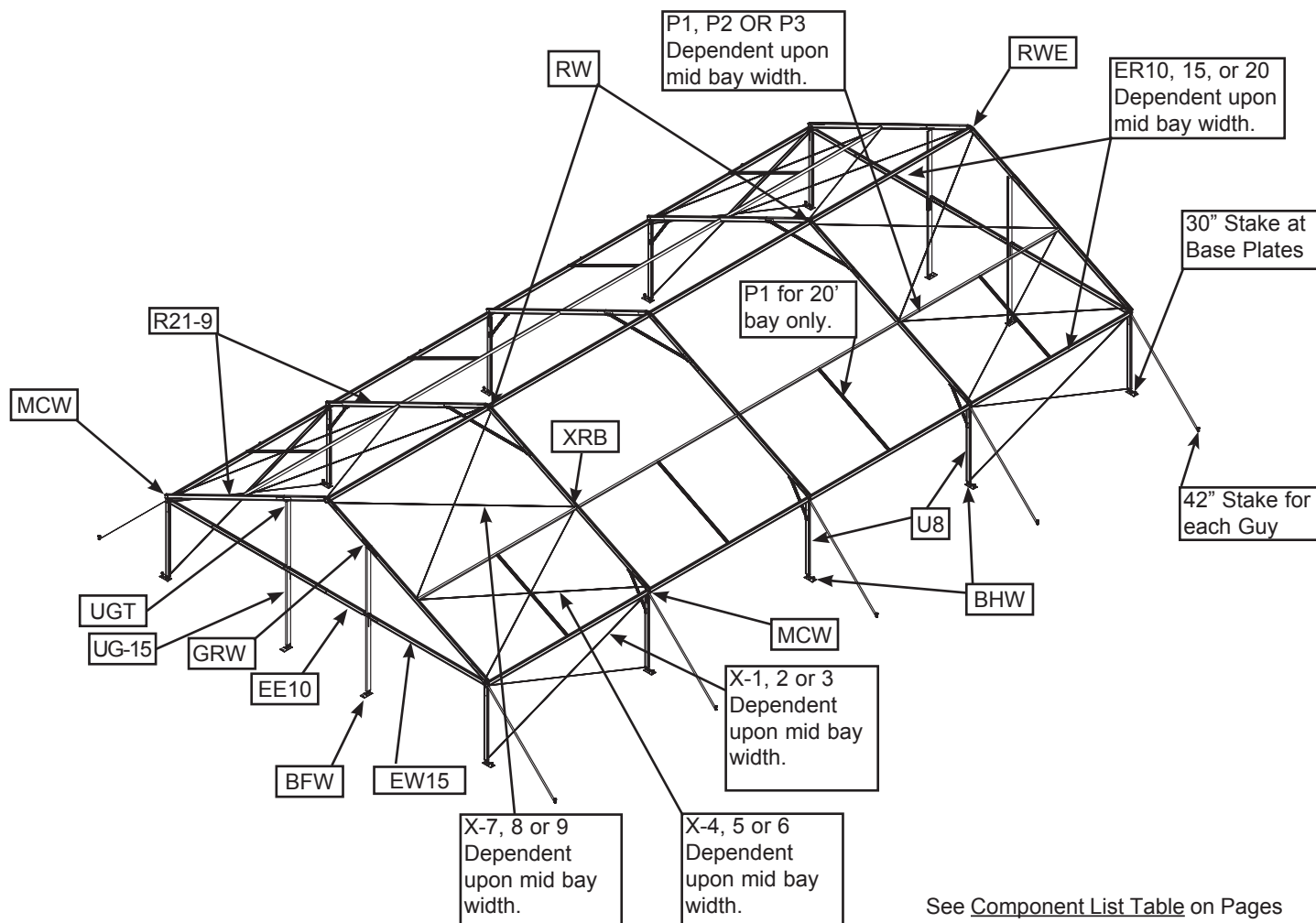

40' NAVI-TRAC COMPONENT ILLUSTRATIONS

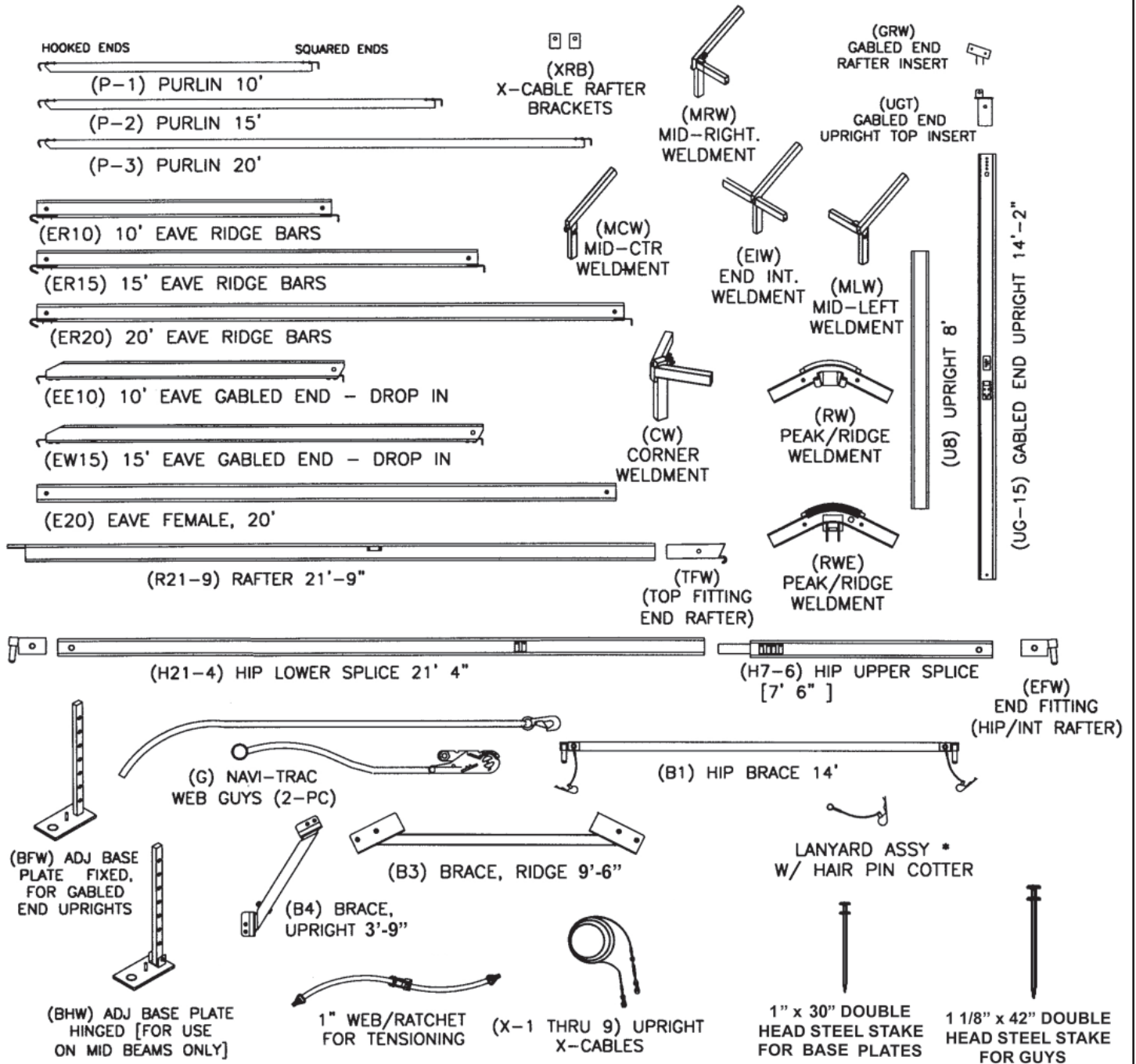

INSTALLATION TOOLS

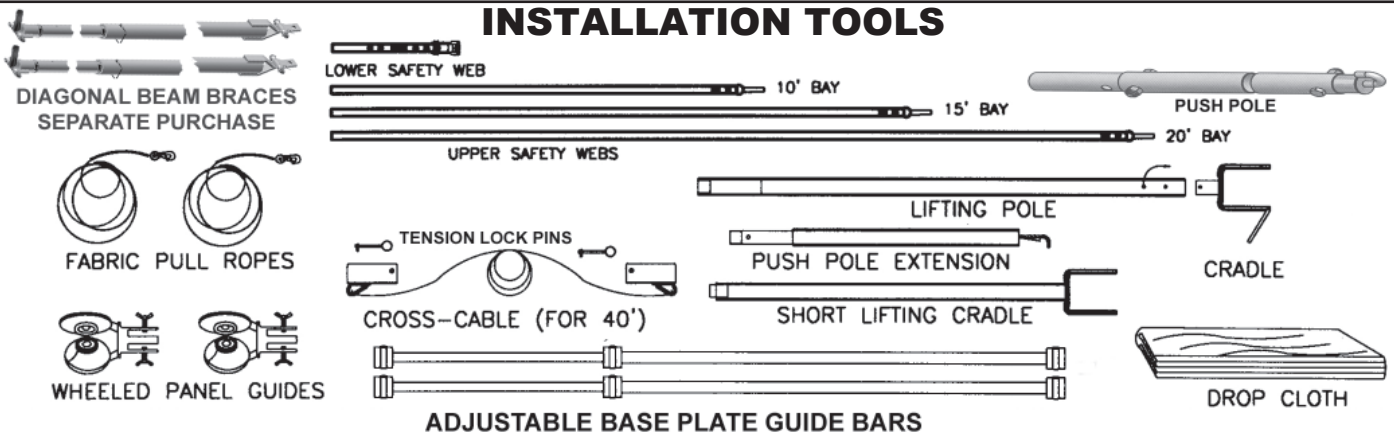

40' NAVI-TRAC COMPONENT LIST

A MINIMUM GABLED UNIT CONSISTS OF (1) KIT #1, (1) KIT #2 AND (2) EXTENSION MIDS. TO EXTEND THE LENGTH FURTHER, SIMPLY ADD ADDITIONAL EXTENSION MIDS. STARTER MIDS REQUIRED WITH HIP ENDS ONLY.

LABEL (LETTER ON DRAWING)	COMPONENT DESCRIPTION	I.D. CODES (STAMPED OR TAPED)	40' GABLED END NAVI-TRAC								
			GBL KIT 1	GBL KIT 2	HIP KIT 3	20' MID STR	20' MID EXT	15' MID STR	15' MID EXT	10' MID STR	10' MID EXT
	EXTRUSIONS W/CHANNELS										
E20	EAVE - FEMALE 20'				4						
ER10	EAVE/RIDGE - DROP-IN 10'									3	3
ER15	EAVE/RIDGE - DROP-IN 15'							3	3		
ER 20	EAVE/RIDGE - DROP-IN 20'					3	3				
EE-10	EAVE/GABLED END, DROP-IN 10'		1	1							
EW-15	EAVE/GABLED END, DROP-IN 15'		2	2							
H21-4	HIP LOWER SPLICE 21-4 (2 pc) 21'-4 (40')				2						
H7-6	HIP UPPER SPLICE (2PC) 7'-6 (40')				2						
R21-9	RAFTER 21'-9		2		1	2	2	2	2	2	2
	BRACES										
B1	BRACE, HIP 14' (W/LANYARDS)				4						
B3	BRACE, RIDGE 9'-6"					1	1	1	1	1	1
B4	BRACE, UPRIGHT, 3'-9"				1	2	2	2	2	2	2
	PURLINS										
P1	PURLIN 10'					2	2			2	2
P2	PURLIN 15'							2	2		
P3	PURLIN 20'					2	2				
	UPRIGHTS										
U8	UPRIGHT - 8'		2		3	2	2	2	2	2	2
UG-15	END UPRIGHT - 14'-2"		2	2							
	WELDMENTS, FITTINGS & PLATES										
BFW	ADJ. BASE PLATES W/INSERTS (FIXED)	"END"	2	2	3	2		2		2	
BHW	ADJ BASE PLATEW/INSERTS (HINGED)		2	2			2		2		2
CW	CORNER WELDMENTS				2						
EIW	END INTERMEDIATE WELDMENTS				1						
MLW	MID LEFT WELDMENTS					2		2		2	
MRW	MID RIGHT WELDMENTS					2		2		2	
MCW	MID CENTER WELDMENTS		2				2		2		2
RW	PEAK/RIDGE WELDMENT					1	1	1	1	1	1
RWE	GABLED END RIDGE WELDMENT		1	1							
GRW	GABLED END UPRIGHT RAFTER WELD.		2	2							
UGT	GABLED END UPRIGHT TOP INSERT		2	2							
XRB	X-CABLE RAFTER BRACKET		8	8							
TFW	TOP FITTING (END RAFTER) W/HDWR				1						
EFW	END FITTING (HIP/INT. RAFTER) W/HDWR				4						

CONTINUED ON NEXT PAGE

40' NAVI-TRAC COMPONENT LIST

CONTINUED FROM PREVIOUS PAGE

LABEL (LETTER ON DRAWING)	COMPONENT DESCRIPTION	I.D. CODES (STAMPED OR TAPED)	40' GABLED END NAVI-TRAC										
			GBL KIT 1	GBL KIT 2	HIP KIT 3	20' MID STR	20' MID EXT	15' MID STR	15' MID EXT	10' MID STR	10' MID EXT		
	CABLES		**OPTIONS OF 10', 15', OR 20' BAYS MUST BE SPECIFIED.										
X-1	UPRIGHT X-CABLES FOR 10' MID BAY**	GREEN NAV-BAY10-U8	[4]	[4]									
X-2	UPRIGHT X-CABLES FOR 15' MID BAY**	GREEN NAV-BAY15-U8	[4]	[4]									
X-3	UPRIGHT X-CABLES FOR 20' MID BAY**	GREEN NAV-BAY20-U8	[4]	[4]									
X4	LOWER ROOF X-CABLES FOR 10' MID BAY A**	RED NAV-BAY10	4	4									
X5	LOWER ROOF X-CABLES FOR 15' MID BAY A**	RED NAV-BAY15	4	4									
X6	LOWER ROOF X-CABLES FOR 20' MID BAY A**	RED NAV-BAY20	4	4									
X7	UPPER ROOF X-CABLES FOR 10' MID BAYS**	BLUE NAV40-BAY10	4	4									
X8	UPPER ROOF X-CABLES FOR 15' MID BAY B**	BLUE NAV40-BAY15	4	4									
X9	UPPER ROOF X-CABLES FOR 20' MID BAY B**	BLUE NAV40-BAY20	4	4									
	BOLTS AND HARDWARE												
	LANYARD ASS'Y W/HAIRPIN COTTER				4								
	1/2"-13 x 3" BOLT W/NYLOCK NUT		6	4	10	2	2	2	2	2	2	2	2
	1/2"-13 x 3 1/2" BOLT W/NYLOCK NUT		6	6									
	INSTALLATION TOOLS												
	CROSS CABLE FOR 40'	BLUE	1	1	1	1		1			1		
	LOWER SAFETY STRAP W/RATCHET		4										
	UPPER SAFETY STRAP FOR 10' BAYS		4										
	UPPER SAFETY STRAP FOR 15' BAYS		4										
	UPPER SAFETY STRAP FOR 20' BAYS		4										
	1/2" TENSION LOCK PIN (FOR CROSS CABLE)		2	2	2	2		2			2		
	LONG LIFTING CRADLE		1										
	PUSH POLE EXT. (FOR LONG CRADLE)		1										
	SHORT LIFTING CRADLE		1										
	ADJ. BASEPLATE GUIDE BAR		2										
	FABRIC PULL ROPES		2										
	WHEELED PANEL GUIDES		2										
	DROP CLOTH (8' x 30')		1										
	(2) DIAGONAL BEAM BRACES (SEPARATE PURCHASE)												

Other component notes:

1. For X-Cables for units 100' or longer, see page 13 for quantities and installation.
2. Stakes and Guys are not included in this table. See staking guidelines on Page 9.

NAVI-TRAC Installation Safety Guidelines

Your installation techniques will evolve to fit the needs of your clients, the experience level of your crews, the nature of other tentage on-site, and the equipment that you have most readily available. We encourage you to begin with a crew of (4) workers and only reduce this number as your experience level allows you to do so safely. Whatever techniques you adapt for your crews, we encourage you to keep safety utmost in mind.

Please read through this assembly manual completely before beginning your installation. Be sure the proper equipment, crew and safety precautions are in place. We hope that you enjoy the design features of the NAVI-TRAC each time the unit is installed.

1. It is recommended that workers wear safety shoes and hard-hats on site.
2. When moving beam sections by hand, use proper lifting techniques to protect the back, and avoid pinching fingers while making hardware connections.
3. Never permit bystanders or uninvolved to stand or walk even briefly in the falling path of a beam as it is being raised or lowered.
4. Be aware to avoid contact of beams with any overhead power lines near the site.
5. When anchoring the structure, avoid all underground power lines and gas lines or other utility easements. Local authorities should be able to map the location of these obstacles.
6. Keep site clear of debris to avoid tripping, especially while carrying components or bundles of fabric.
7. Do not drag bundles of fabric on concrete, asphalt, or ground as this can cause damage to the fabric from abrasion through the bag.
8. When lifting the NAVI-TRAC Hip End frame (See Appendix), be sure to use the heavy duty NAVI-TRAC frame lift. The standard Anchor frame lift was not designed for the weight of the NAVI-TRAC frame. When lifting each side of an end section, (2) NAVI-TRAC frame lifts should be used.
9. Before pivoting beams to vertical, clear the area of items that could cause tripping or slipping.
10. Before pivoting middle beam, install the cross-cable for safety bracing. On the 50' NAVI-TRAC, the cross-cable should be left in place as an essential part of the structure.
11. NOTE: Hinged baseplates are used on all beams in the Gabled End Configuration. However, if the Hip End is constructed on either, or both ends of the unit, the base plates in the hip end module should all be the non-pivoting, fixed plates. Use of hinged baseplates in the end module could cause the end module to collapse during installation.
12. When using ladders to make peak connections, be sure the ladder is tall enough that workers can reach the peak from a ladder step consistent with the safety recommendations for the ladder being used. On middle beams, secure the eaves before climbing the ladder to secure the peak.
13. For any Gabled End NAVI-TRAC of 100 ft or more in length, one middle bay must be cross-cabled both in the over head and at ground level in an "X" fashion on both sides for each 100 ft of length (see illustration on page 16).
14. For proper loading and anchoring information, consult the appropriate NAVI-TRAC blueprint available from Anchor Industries Inc.
15. If a Hip End is used on either end of the unit, before installing fabric, verify that all hip, brace, and rafter pins are seated into weldment fittings and secured by lanyard pins.
16. **The installation method described herein requires coordination of tasks between workers. A safe installation is dependent on alertness and coordination.**
17. Before lifting Gabled End top frame to install uprights, **always guy out and stake at least both corners** of the side or end being lifted. This will help maintain the intended footprint and will protect against uplift from the wind that could move or flip the tent, **causing damage to the tent and/or severe injury to workers.**

SQUARING THE TENT FOOTPRINT LAYOUT

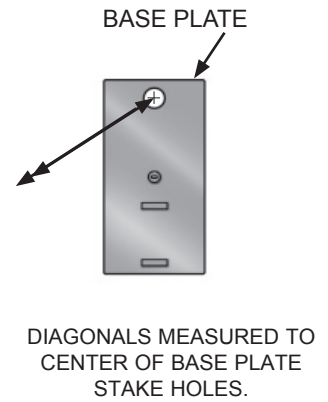
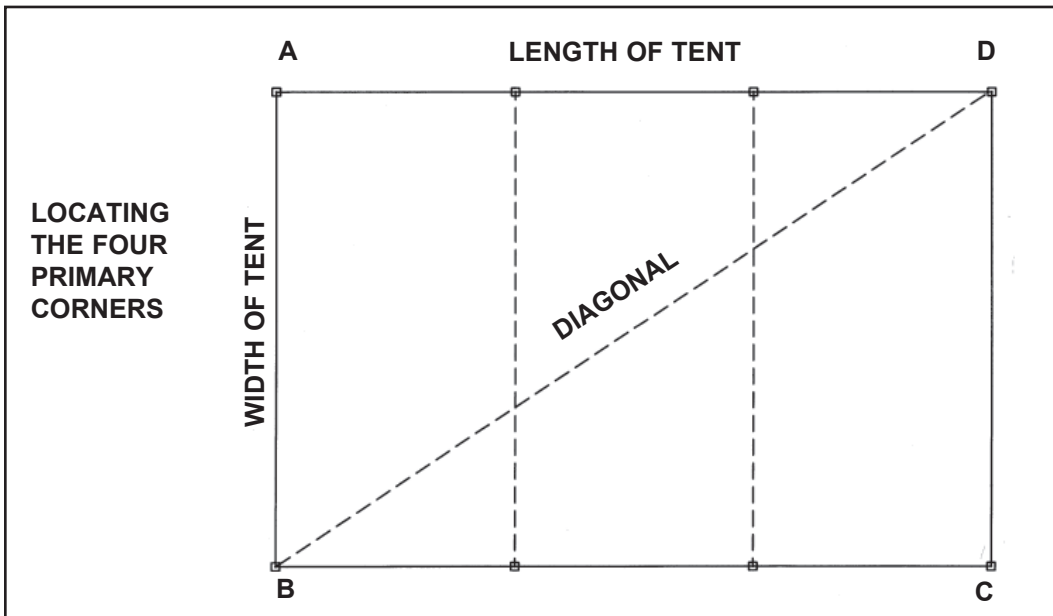

DIRECTIONS FOR SQUARING THE TENT

1. USE A TAPE MEASURE TO MARK THE ENDS OF A LINE FOR ONE END ("A" TO "B" ABOVE) EQUAL TO THE EXACT WIDTH OF THE UNIT. NOTE: FOR EASIER INSTALLATION, MARK THE WIDTH FROM STAKE HOLE TO STAKE HOLE OF THE BASEPLATES, AS SHOWN IN BELOW CHART.
2. HOLD THE "0" END OF ONE TAPE AT POINT "A" AND THE "0" END OF ANOTHER TAPE AT POINT "B".
3. EXTEND THE FIRST TAPE ALONG ONE SIDE OF THE UNIT TO A MEASUREMENT EQUAL TO THE EXACT LENGTH OF THE TENT.
4. CONSULT THE CHART BELOW TO FIND THE DIAGONAL FOR THE TENT YOU ARE BUILDING.
5. EXTEND THE SECOND TAPE TO A MEASUREMENT EXACTLY EQUAL TO THIS DIAGONAL.
6. BRING THE TWO TAPES TOGETHER SO THAT THE LENGTH MEASUREMENT OF ONE LIES DIRECTLY ON THE DIAGONAL MEASUREMENT OF THE OTHER. PULL THE TAPES TIGHT AND MARK THEIR INTERSECTION. THIS WILL LOCATE A FAR CORNER (POINT "D" ABOVE).
7. SWITCH TAPES SO THAT TAPE 1 (ABOVE) MEASURES THE DIAGONAL AND TAPE 2 (ABOVE) MEASURES THE LENGTH. THIS WILL LOCATE POINT "C" ABOVE.
8. WITH THE FOUR PRIMARY CORNERS LOCATED, LAY OUT BASEPLATES AND UPRIGHTS ACCORDING TO THE NUMBER OF BEAMS TO BE INCLUDED IN THE BUILDING UNIT. MEASUREMENTS GIVEN ARE TO THE CENTER OF THE STAKE HOLE OF EACH PLATE.

DIAGONALS FOR SQUARING FOOTPRINT

LENGTH OF TENT

FEET	30	40	45	50	55	60	65	70	75	80	85	90	95	100	105	110	115	120	125	130
31	43' 2"	50' 7"	54' 8"	58' 10"	63' 2"	67' 6"	72' 0"	76' 7"	81' 2"	85' 10"	90' 6"	95' 2"	99' 11"	104' 8"	109' 6"	114' 3"	119' 1"	123' 11"	128' 9"	133' 8"
41	50' 10"	57' 3"	60' 11"	64' 8"	68' 7"	72' 8"	76' 10"	81' 1"	85' 6"	89' 11"	94' 4"	98' 11"	103' 6"	108' 1"	112' 9"	117' 5"	122' 1"	126' 10"	131' 7"	136' 4"
51	59' 2"	64' 10"	68' 0"	71' 5"	75' 0"	78' 9"	82' 7"	86' 7"	90' 8"	94' 10"	99' 2"	103' 5"	107' 10"	112' 3"	116' 9"	121' 3"	125' 10"	130' 5"	135' 0"	139' 8"

DIAGONAL SHOWN IN FEET-INCHES (TO NEAREST INCH) - - TO CENTERS OF STAKE HOLES.

FEET	135	140	145	150	155	160	165	170	175	180	185	190	195	200	205	210	215	220	225	230
31	138' 6"	143' 5"	148' 3"	153' 2"	158' 1"	163' 0"	167' 11"	172' 10"	177' 9"	182' 8"	187' 7"	192' 6"	197' 5"	202' 5"	207' 4"	212' 3"	217' 3"	222' 2"	227' 2"	232' 1"
41	141' 1"	145' 11"	150' 8"	155' 6"	160' 4"	165' 2"	170' 0"	174' 10"	179' 9"	184' 7"	189' 6"	194' 4"	199' 3"	204' 2"	209' 1"	214' 0"	218' 10"	223' 9"	228' 8"	233' 8"
51	144' 4"	149' 0"	153' 8"	158' 5"	163' 2"	167' 11"	172' 8"	177' 6"	182' 3"	187' 1"	191' 11"	196' 9"	201' 7"	206' 5"	211' 3"	216' 1"	221' 0"	225' 10"	230' 8"	235' 7"

WIDTH OF TENT
(STAKE HOLE TO
STAKE HOLE)

WEB GUY - STAKING GUIDELINES

REQUIRED DISTANCE OUT BETWEEN FRAME UPRIGHTS AND STAKE LINE IS EQUAL TO THE UPRIGHT HEIGHT. (FOR EXAMPLE, 8' UPRIGHT = 8' STAKE-OUT DISTANCE.)

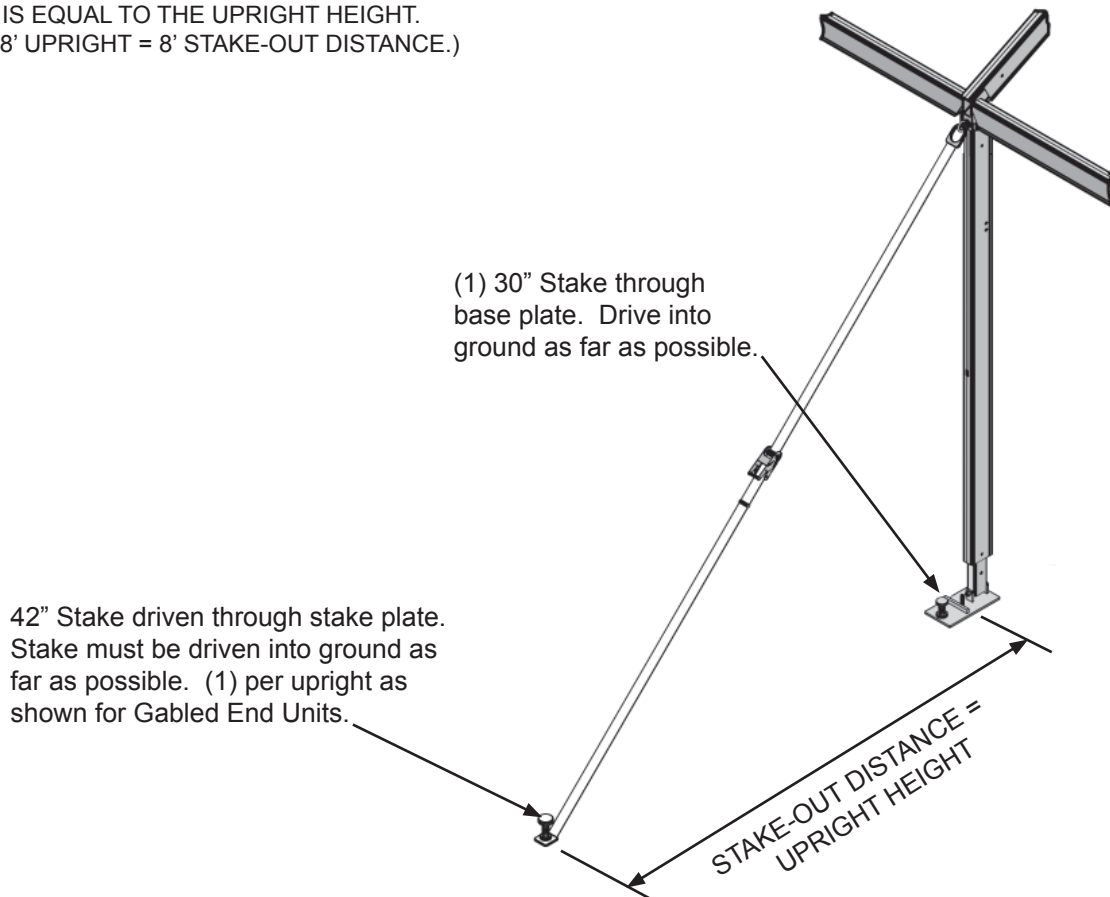

ASSEMBLE FIRST BEAM

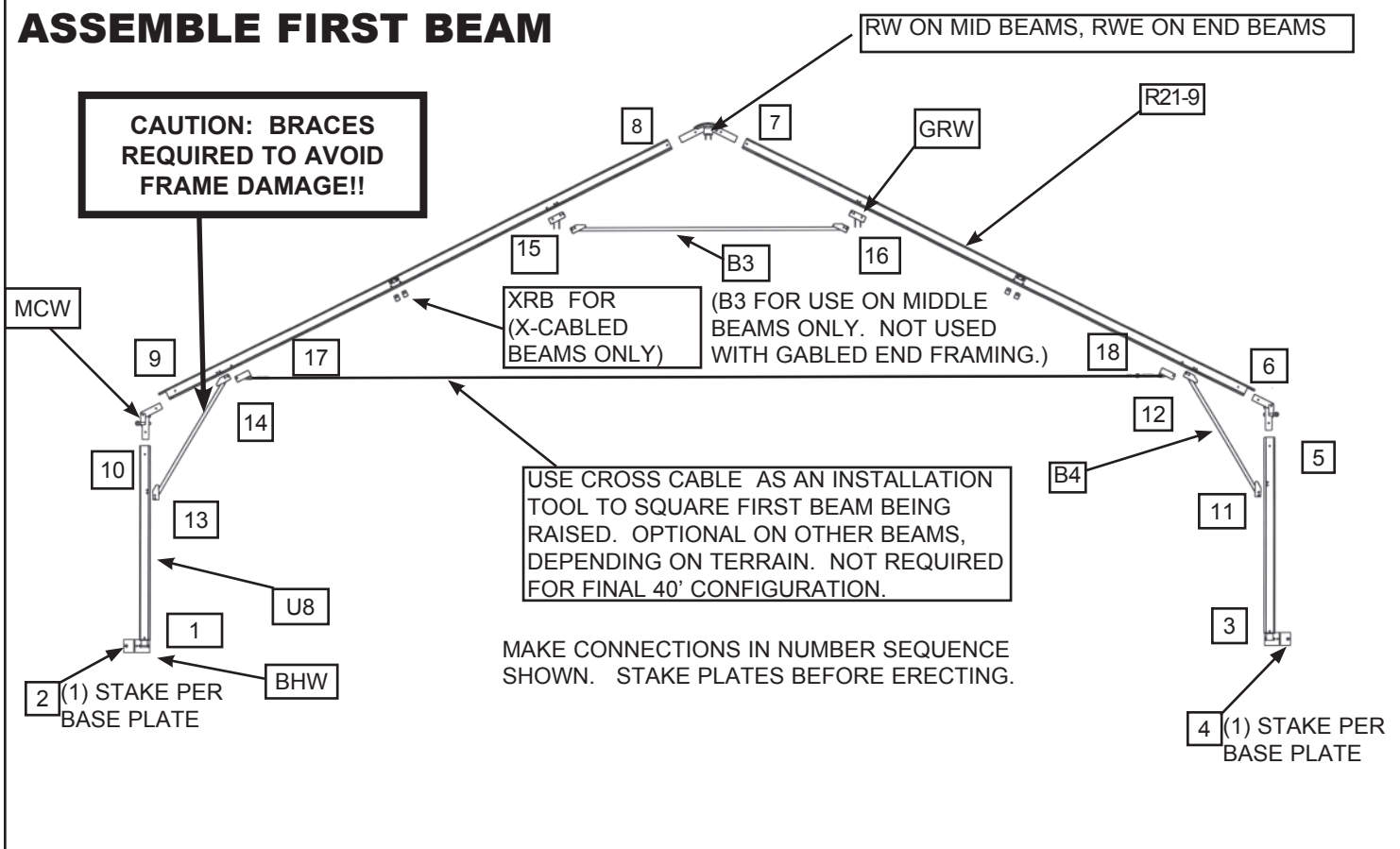

LAYOUT OF ALL BEAMS

IMPORTANT NOTE: IF YOU WILL BE USING THE **OPTIONAL DIAGONAL BEAM BRACES**, LAY OUT ALL BEAMS IN THE SAME DIRECTION, DO NOT BUTTERFLY. SEE DIAGONAL BEAM BRACE USE AT THE BACK OF THIS MANUAL.

CROSS CABLE USED FOR SQUARING FIRST BEAM BEING RAISED. OPTIONAL ON OTHER BEAMS. NOT REQUIRED FOR FINAL UNIT CONFIGURATION.

ALL BASE PLATES ARE STAKED USING 30" STAKES.

UPPER ENDS OF ALL X-CABLES ATTACHED BEFORE BEAMS ARE RAISED.

FIRST (2) BEAMS BUTTERFLIED SO THAT ADJACENT BASE PLATE STAKES CAN BE USED FOR SAFETY GUYING. (2ND BEAM WILL BE RAISED FIRST.)

ADJUST BASE PLATE GUIDE BARS FOR PROPER SPACING AND ALIGNMENT OF BASEPLATES. (DROP BAR FITTING OVER PINS IN BASE PLATES.)

2-PC SAFETY WEBS:

1. LOOP (4) LOWER SAFETY WEBS OVER STAKE HEADS OF THE ADJACENT BASE PLATES, BEAMS 1 & 3 (RATCHET ENDS UP).
2. CHOOSE (4) UPPER SAFETY WEBS LABELED FOR 10', 15', OR 20' BAY SPACING, AS NEEDED FOR YOUR UNIT.
3. ON THE TRAILING WEBS (TO BEAM #3), INSERT THE LOOSE, HANGING ENDS OF UPPER WEBS INTO THE RATCHETS OF THE LOWER SAFETY WEBS. PULL ABOUT 1 FT OF WEB THRU THE RATCHET. LEAVE PLENTY OF SLACK.
4. SNAP UPPER ENDS OF UPPER WEBS TO THE EAVE BRACKETS OF THE BEAM TO BE RAISED.
5. LEAVE THE LEADING WEBS (TO BEAM #1) LOOSE AND HANGING UNTIL BEAM IS UP.

ERECTING 2nd BEAM 1st

ATTACH PUSH POLE EXTENSION TO TOP OF THE LONG LIFTING POLE. HOOK INTO PEAK WELDMENT BRACKET & TWIST TO SECURE. THIS WORKER CONTROLS PEAK DURING ERECTION.

WORKERS LIFT FIRST AT THE PEAK, THEN SHUFFLE SIDWAYS TOWARD THE UPRIGHTS.

AS THE 2ND BEAM PIVOTS TOWARD VERTICAL, THE TRAILING SAFETY WEBS DRAW TIGHTER.

SECURING THE 1st VERTICAL BEAM

ON THE LEADING 2-PC SAFETY WEBS, WORKERS INSERT LOOSE ENDS OF UPPER SAFETY WEBS INTO THE RATCHETS OF THE LOWER SAFETY WEBS.

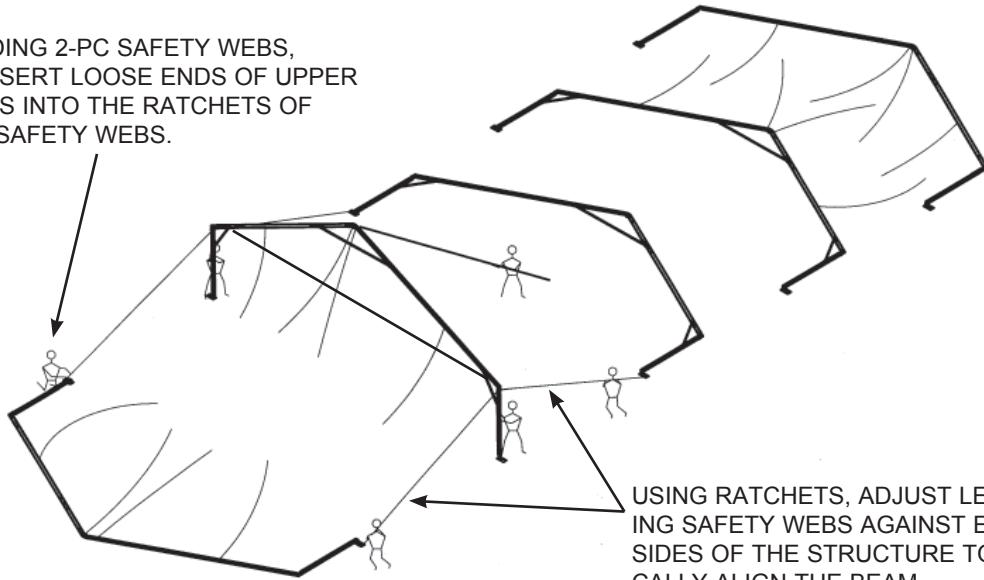

USING RATCHETS, ADJUST LEADING AND TRAILING SAFETY WEBS AGAINST EACH OTHER ON BOTH SIDES OF THE STRUCTURE TO SECURE AND VERTICALLY ALIGN THE BEAM.

ERECTING THE 2nd BEAM

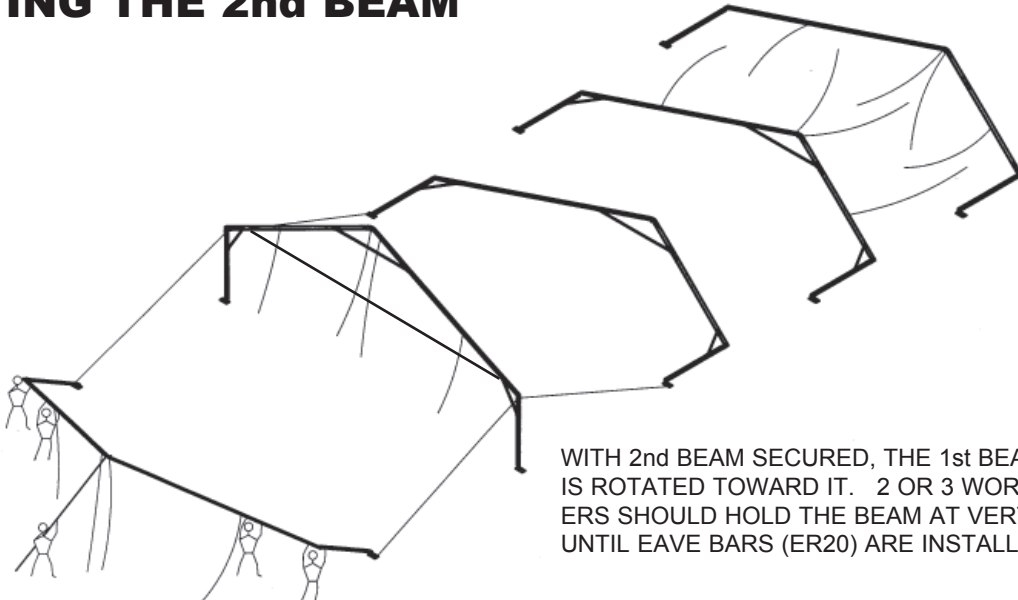

WITH 2nd BEAM SECURED, THE 1st BEAM IS ROTATED TOWARD IT. 2 OR 3 WORKERS SHOULD HOLD THE BEAM AT VERTICAL UNTIL EAVE BARS (ER20) ARE INSTALLED.

SECURING THE 2nd BEAM WITH DROP-IN RIDGE/EAVE BARS

DROP ONE HOOK END OF BAR INTO EAVE FITTING.

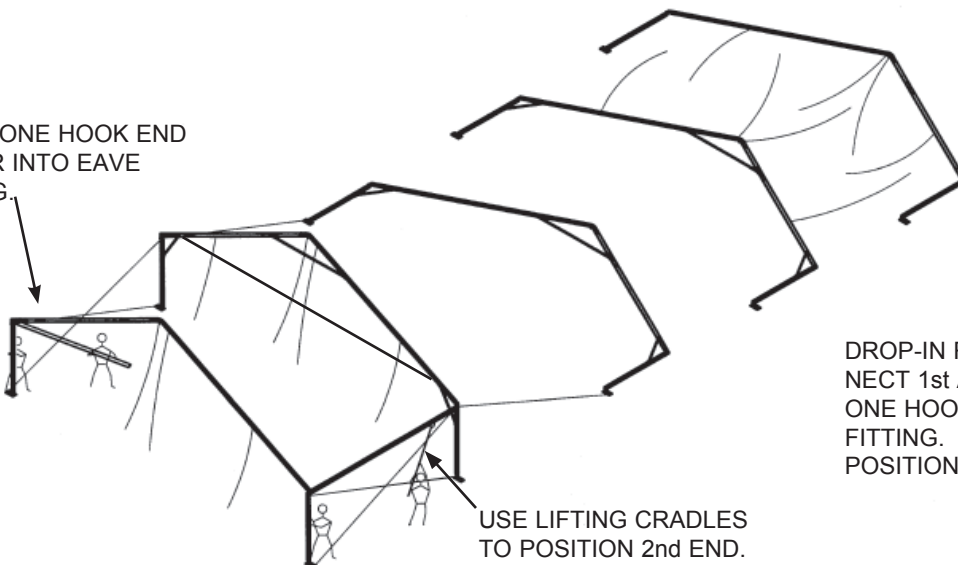

USE LIFTING CRADLES TO POSITION 2nd END.

DROP-IN RIDGE/EAVE BARS CONNECT 1st AND 2nd BEAMS. DROP ONE HOOK END OF BAR INTO EAVE FITTING. USE LIFTING CRADLES TO POSITION 2nd END.

INSTALLING PURLINS AND RIDGE BARS

USE SAME TECHNIQUE AND THE LONG LIFTING POLE WITH CRADLE TO INSTALL THE PURLINS AND RIDGE EAVE BAR (AT THE PEAK)

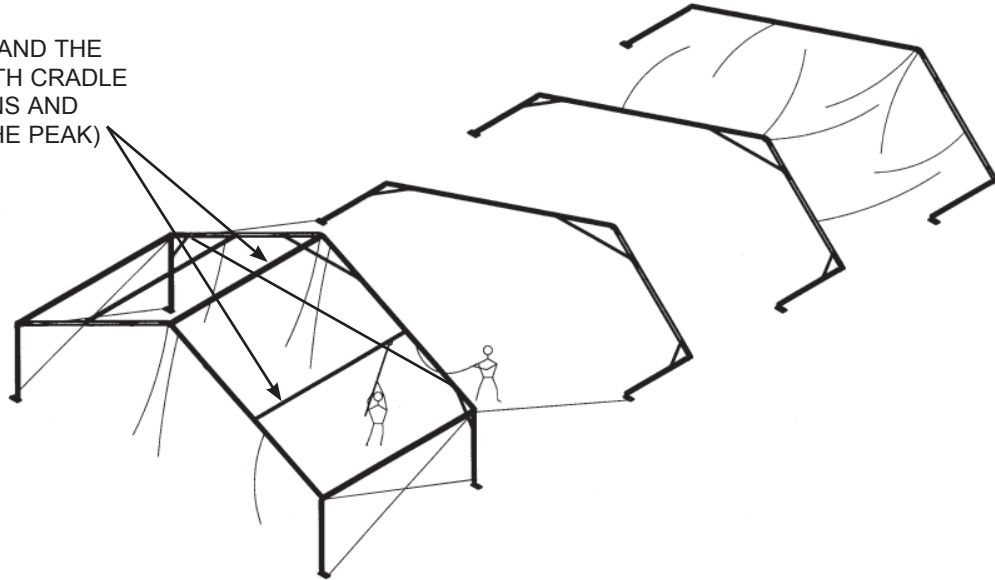

COMPLETING THE 1ST BAY

REMOVE CROSS-CABLE FROM 2ND BEAM

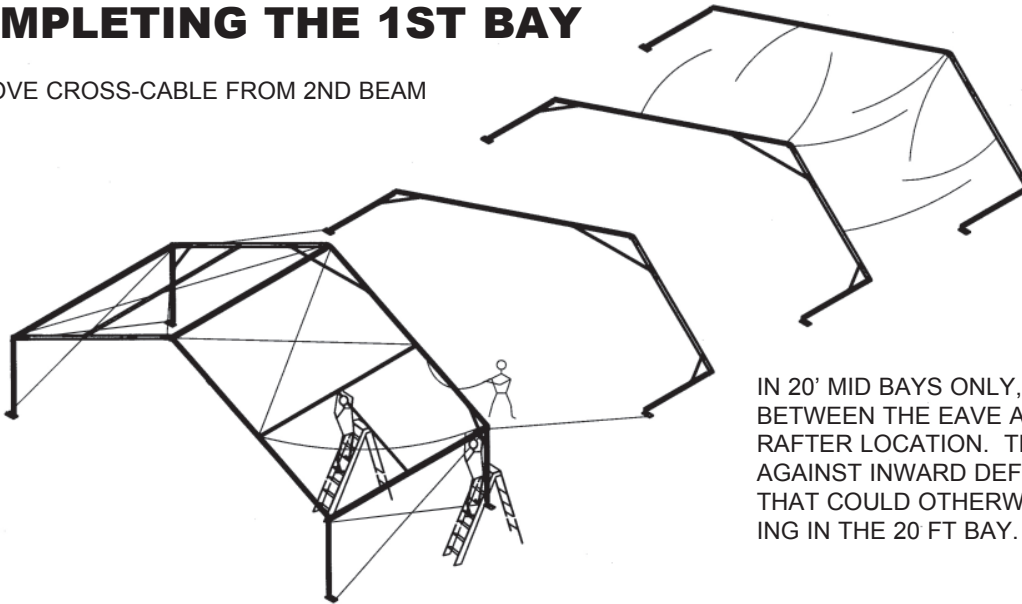

IN 20' MID BAYS ONLY, INSTALL A SUPPORT PURLIN BETWEEN THE EAVE AND THE PURLIN AT THE MID-RAFTER LOCATION. THIS SUPPORT WILL BRACE AGAINST INWARD DEFLECTION OF THE EAVE BAY THAT COULD OTHERWISE RESULT IN WATER PONDING IN THE 20 FT BAY.

COMPLETING THE TOP FRAME

REPEAT PREVIOUS STEPS UNTIL ALL BEAMS ARE VERTICAL AND BOTH END BAYS ARE X-CABLED, AS SHOWN.

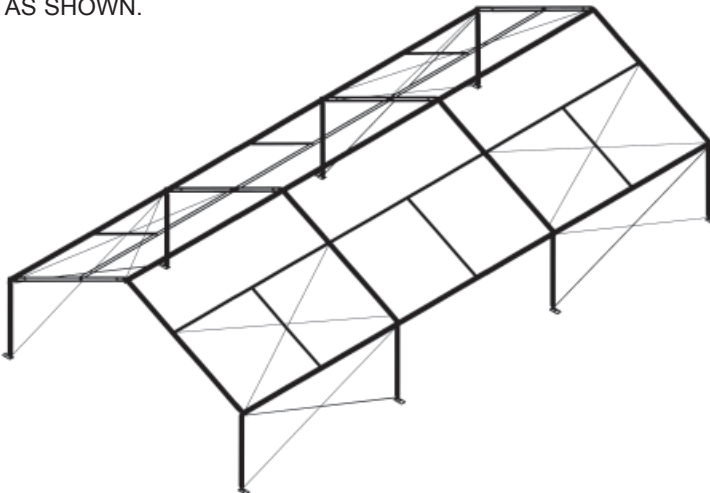

INSTALLING GABLED END FRAME

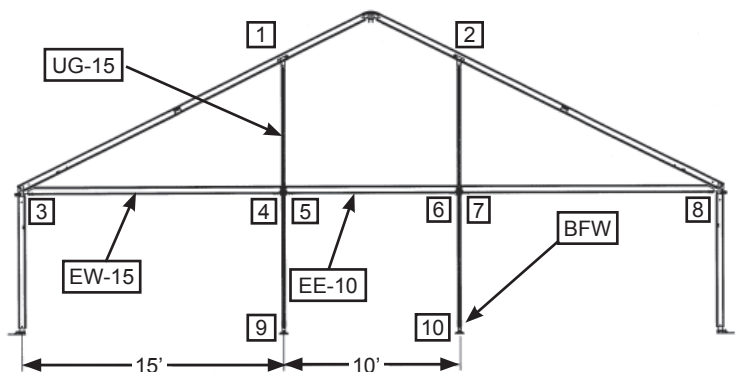

INSTALL GABLED END FRAME. MAKE CONNECTIONS IN THE ORDER SHOWN.

INSTALLING GUY WEBS BEFORE INSTALLING FABRIC

ATTACH GUY WEBS TO EAVE WELDMENTS AND STAKE OUT AT 45°. SEE STAKING GUIDELINES ON PAGE 9.

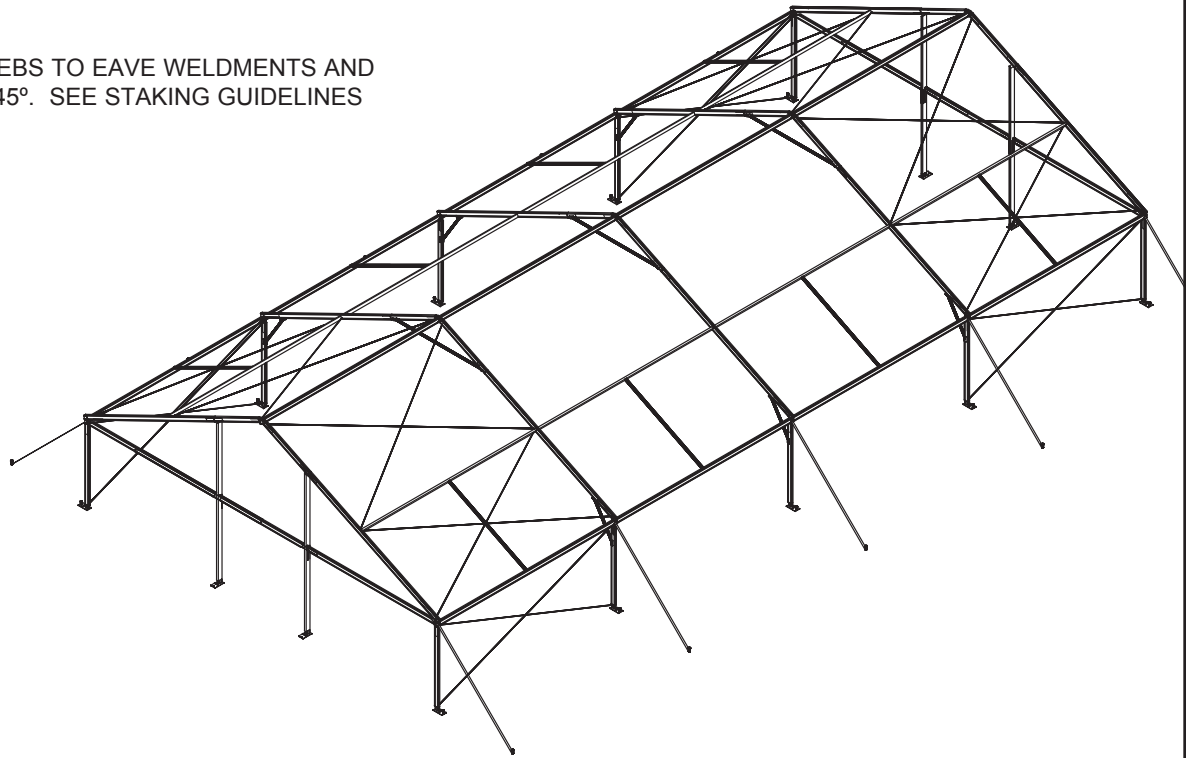

*** IMPORTANT NOTE:** REFER TO CAUTION STATEMENT #2 FOR IMPORTANT WARNING ABOUT NUMBER OF STAKES SUPPLIED. (SEE BACK PAGE OF THIS MANUAL)

THE INSTALLER MUST USE THE LOCAL SOIL CONDITIONS TO CALCULATE THE ACTUAL NUMBER OF STAKES REQUIRED AND IS RESPONSIBLE FOR THE STAKING PATTERN AND CONFIGURATION. ANCHOR PROVIDES ANCHORING PACKAGES FOR COMMON SOIL CLASSIFICATIONS; CONTACT YOUR TENT SALES REPRESENTATIVE FOR MORE INFORMATION.

X-CABLED BAYS

FOR CABLE CONNECTIONS AT MID PORTION OF RAFTERS, INSERT THE BOLTS IN THE HOLES OF THE RAFTER THAT ARE JUST ABOVE AND JUST BELOW THE PURLIN CONNECTION. THREADS SHOULD POINT INWARD TOWARD EACH OTHER. THREAD CABLE EYE NUTS ONTO EACH BOLT TO SECURE THE CABLES AS SHOWN.

LOWER RAFTER X-CABLES ARE COLOR-CODED RED AND LABELED 10, 15, OR 20 ACCORDING TO BAY SIZE.

UPRIGHT X-CABLES ARE COLOR-CODED GREEN AND LABELED 10, 15, OR 20 ACCORDING TO BAY SIZE.

STAKE PLATES AT PROPER SPACING BEFORE INSTALLING THE X-CABLES. THEN, ADJUST TURNBUCKLES UNTIL CABLE IS SNUG

UPPER RAFTER X-CABLES ARE COLOR-CODED BLUE AND LABELED 10, 15, OR 20 ACCORDING TO BAY SIZE.

NAVI-TRAC UNITS 100 FT. OR MORE IN LENGTH MUST HAVE AN X-CABLED BAY NEAR THE MIDDLE OF THE UNIT (AND/OR EQUALLY SPACED) FOR EVERY 100 FT. UNIT OF LENGTH.

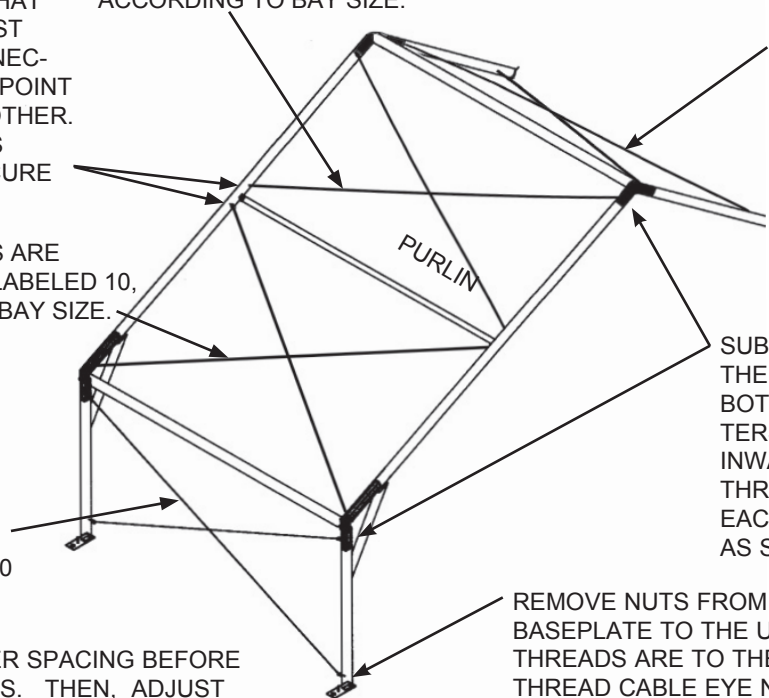

X-CABLING IS IDENTICAL ON BOTH SIDES OF THE STRUCTURE.

SUBSTITUTE BOLTS FOR PINS AT THE TOP OF BOTH UPRIGHTS AND BOTTOM AND TOP OF BOTH RAFTERS. THREADS SHOULD POINT INWARD TOWARD EACH OTHER. THREAD CABLE EYE NUTS ONTO EACH BOLT TO SECURE THE CABLES AS SHOWN.

REMOVE NUTS FROM THE BOLTS THAT PIN THE BASEPLATE TO THE UPRIGHT. TURN BOLTS SO THE THREADS ARE TO THE INSIDE (FACING EACH OTHER). THREAD CABLE EYE NUTS ONTO BOLTS TO SECURE THE CABLE.

INSTALLING MID PANEL

PULL MID PANEL UP AND OVER THROUGH CHANNELS IN RAFTER EXTRUSIONS.

NOTE: PULL ROPES MUST BE SNAPPED TO WEB PULL LOOP ON UNDERNEATH SIDE, JUST BELOW EAVE ON MIDS. DO NOT ATTACH TO RINGS.

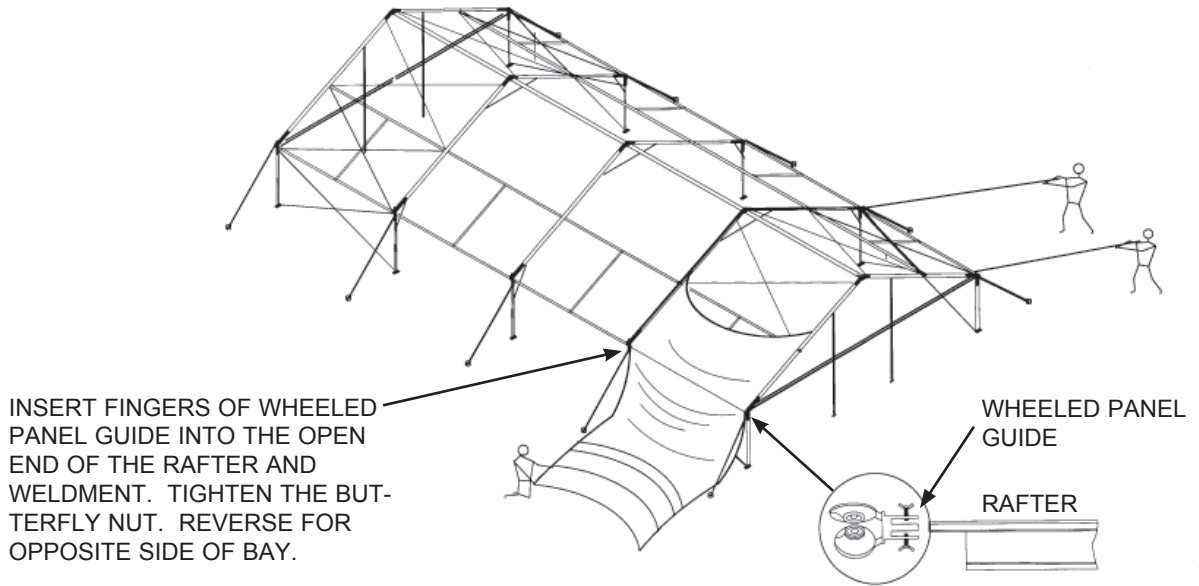

INSTALLING 2-PC GABLED END

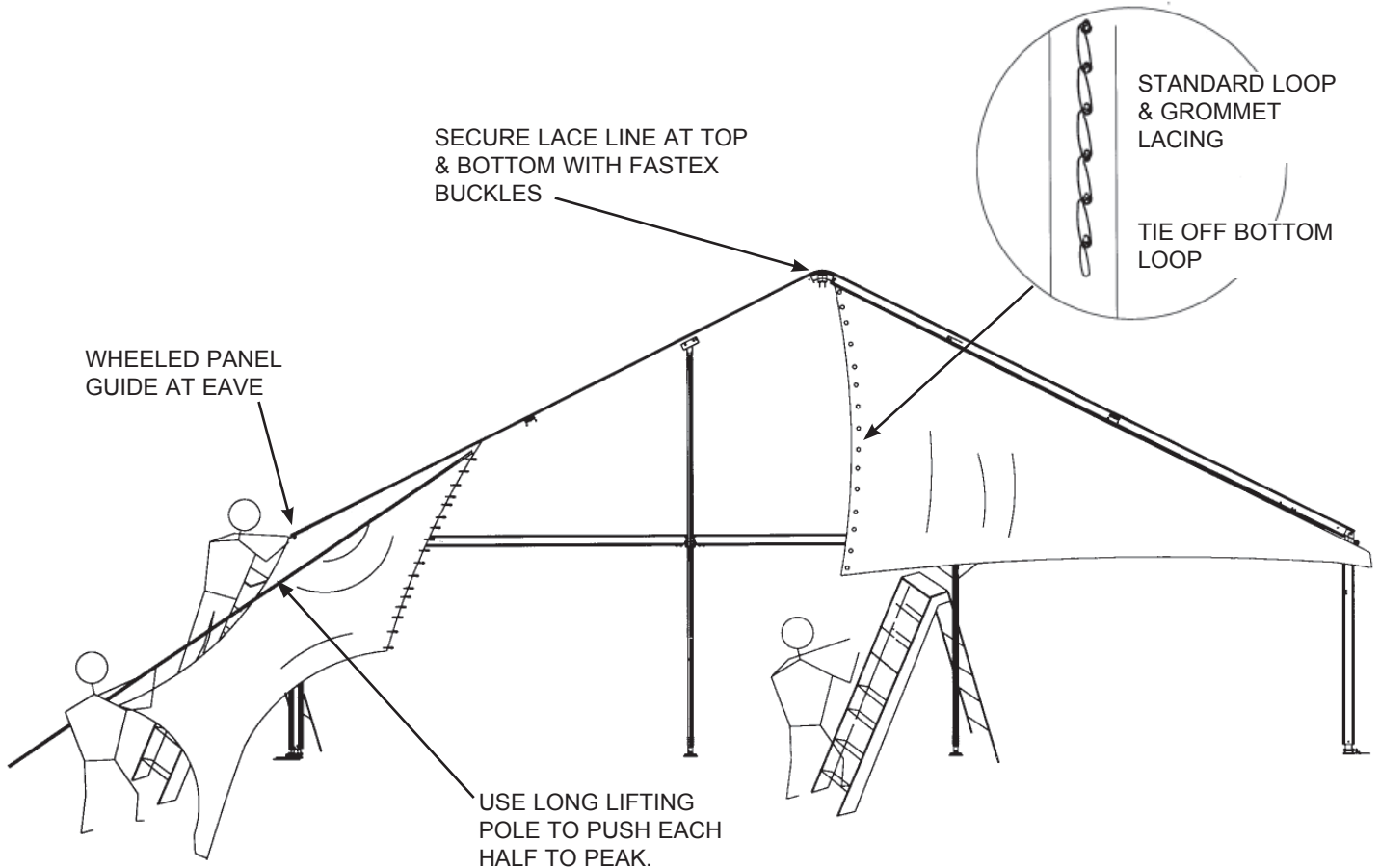

FABRIC TENSIONING

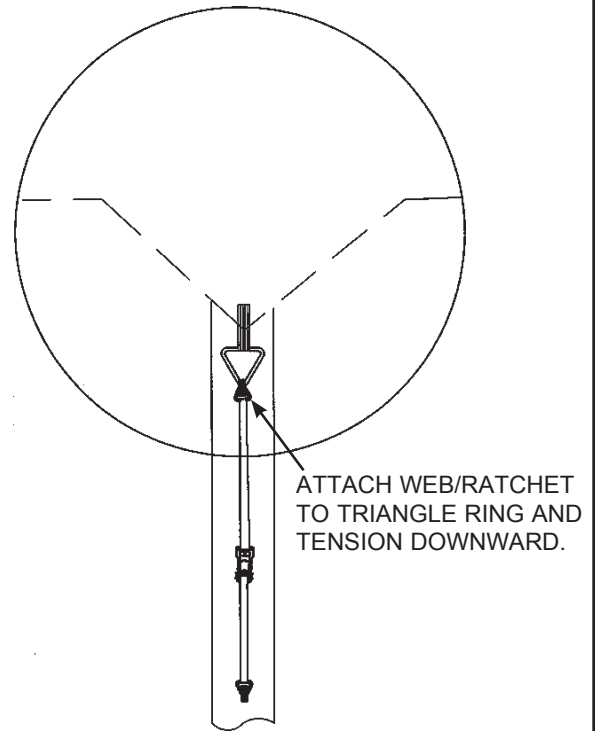
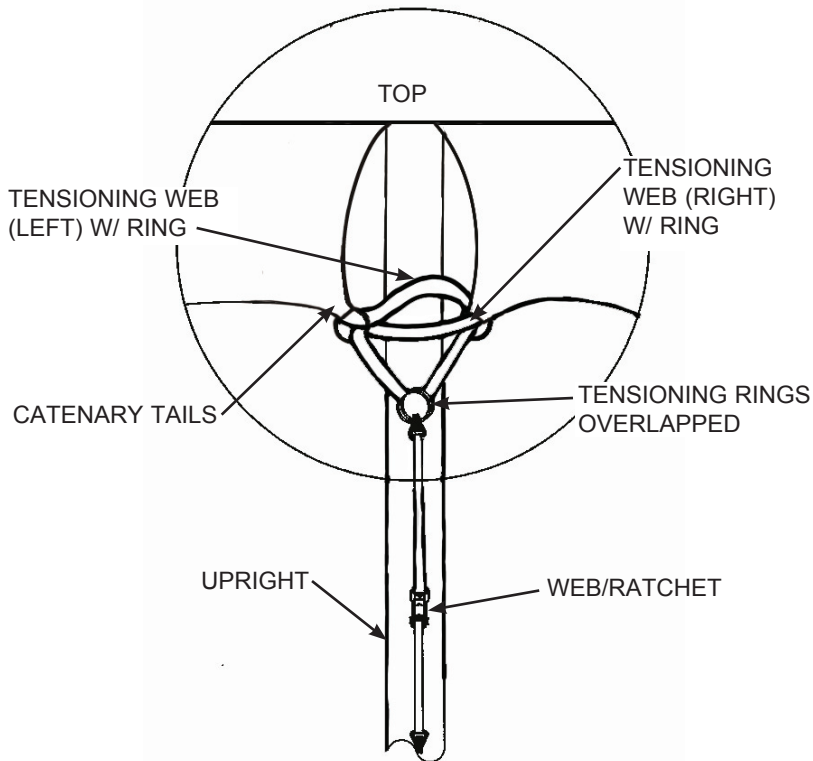

1. USE WEB/ RATCHETS TO SECURE CATENARY ARCHES TO UPRIGHTS, STAKE BASEPLATES BEFORE TENSIONING WEBS.

TENSIONING METHOD:

1. PASS RING OF LEFT TENSIONING WEB THROUGH OPPOSITE CATENARY RING.
2. PASS RING OF RIGHT TENSIONING WEB THROUGH ITS OWN CATENARY RING (PASSING OVER THE LEFT WEB).
3. CONTINUE RING OF RIGHT TENSIONING WEB THROUGH OPPOSITE CATENARY RING.
4. OVERLAP BOTH TENSION RINGS. ATTACH WEB/RATCHET AND TENSION DOWNWARD AGAINST TENSION HOLE IN UPRIGHT. (CATENARY RINGS SHOULD MOVE CLOSER TOGETHER AS RATCHET IS TIGHTENED.)

40' x 80' GABLED END NAVI-TRAC

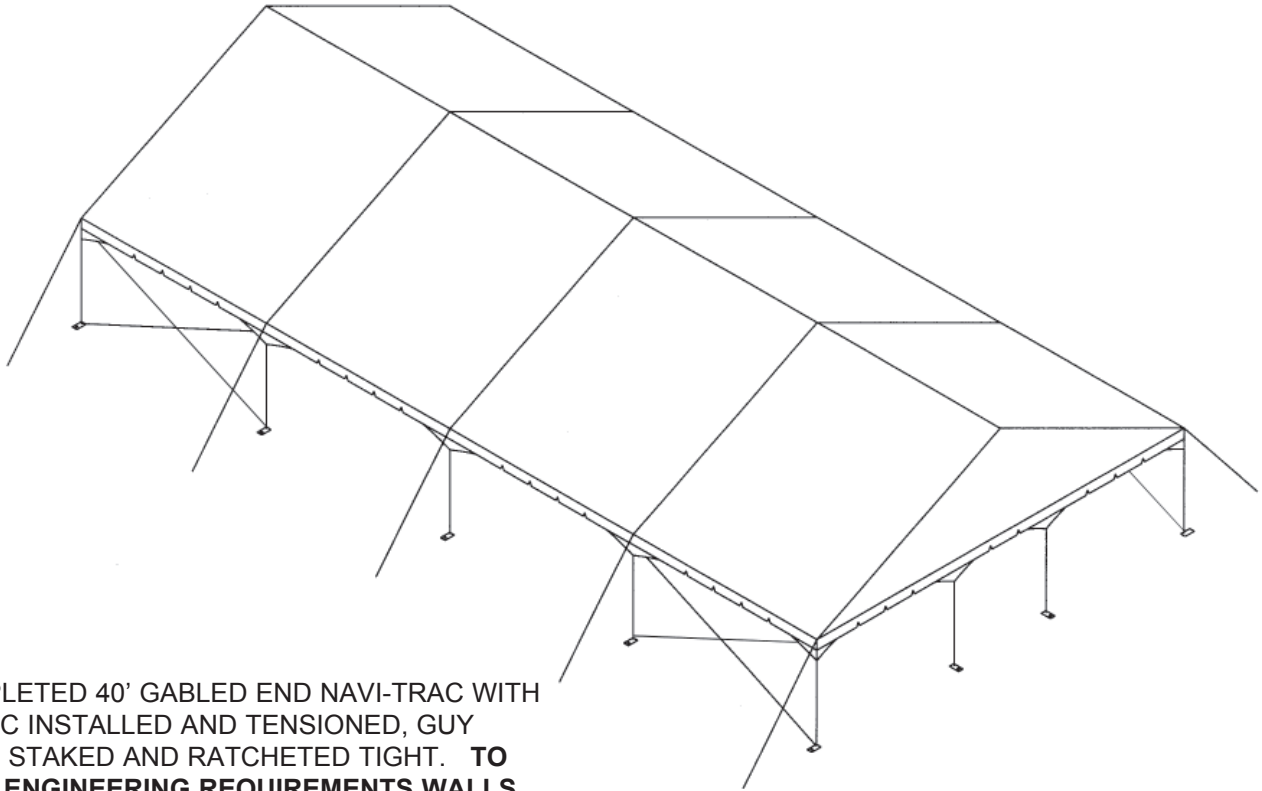

COMPLETED 40' GABLED END NAVI-TRAC WITH FABRIC INSTALLED AND TENSIONED, GUY WEBS STAKED AND RATCHETED TIGHT. **TO MEET ENGINEERING REQUIREMENTS WALLS SHOULD BE INSTALLED ON ALL (4) SIDES.**

ALTERNATE HIP/GABLED END COMBINATION USING KIT #3 FOR THE HIP COMPONENTS (SEE THE FOLLOWING PAGE FOR ASSEMBLY REFERENCE)

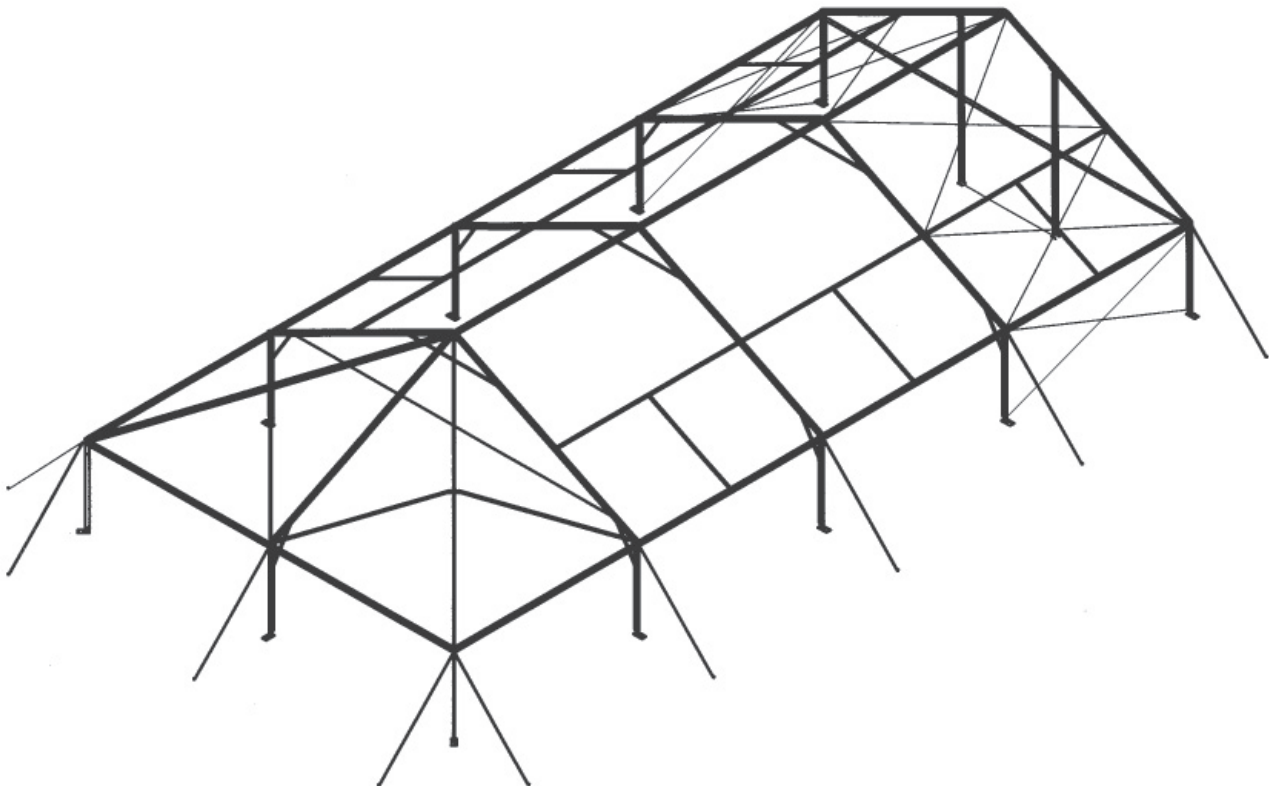

HIP/GABLED END COMBINATION UNIT

SEE THE STANDARD NAVI-TRAC
INSTALLATION INSTRUCTIONS FOR
ASSEMBLY OF THE HIP END UNIT.

EXTENSION BEAMS ARE PIVOTED
IN THE SAME MANNER AS SHOWN
ABOVE IN THIS GABLED END
ASSEMBLY INSTRUCTION.

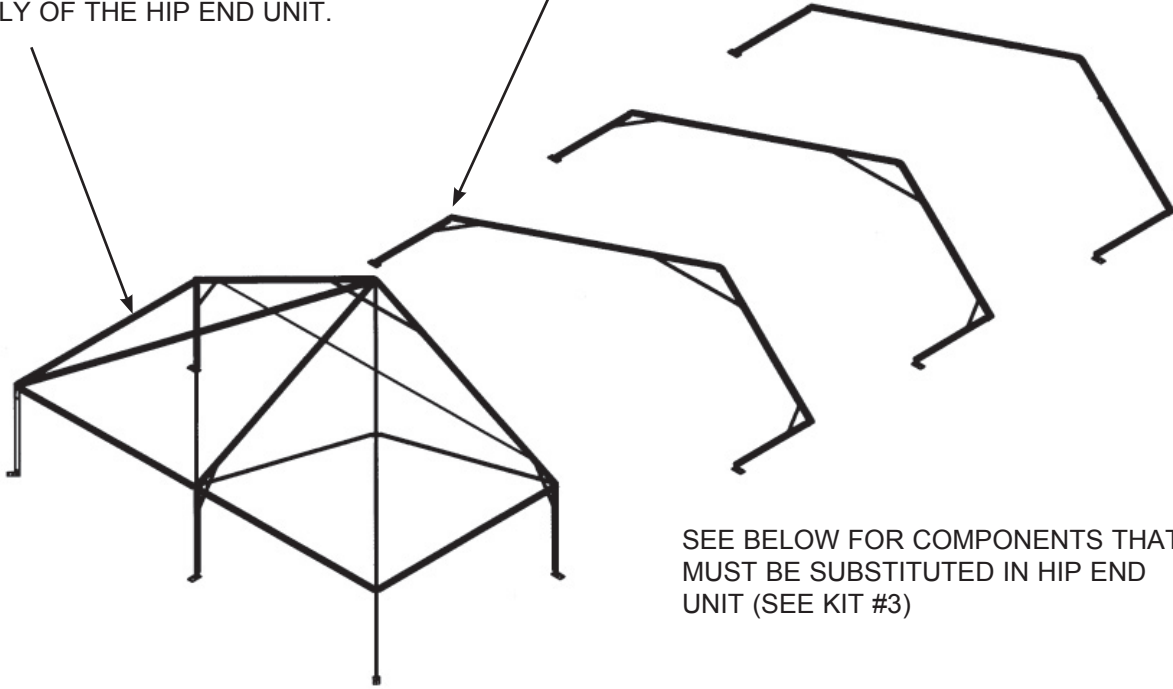

HIP (KIT #3) COMPONENTS

(NOTE: MRW & MLW ARE SUPPLIED
WITH THE "STARTER" FRAMES)

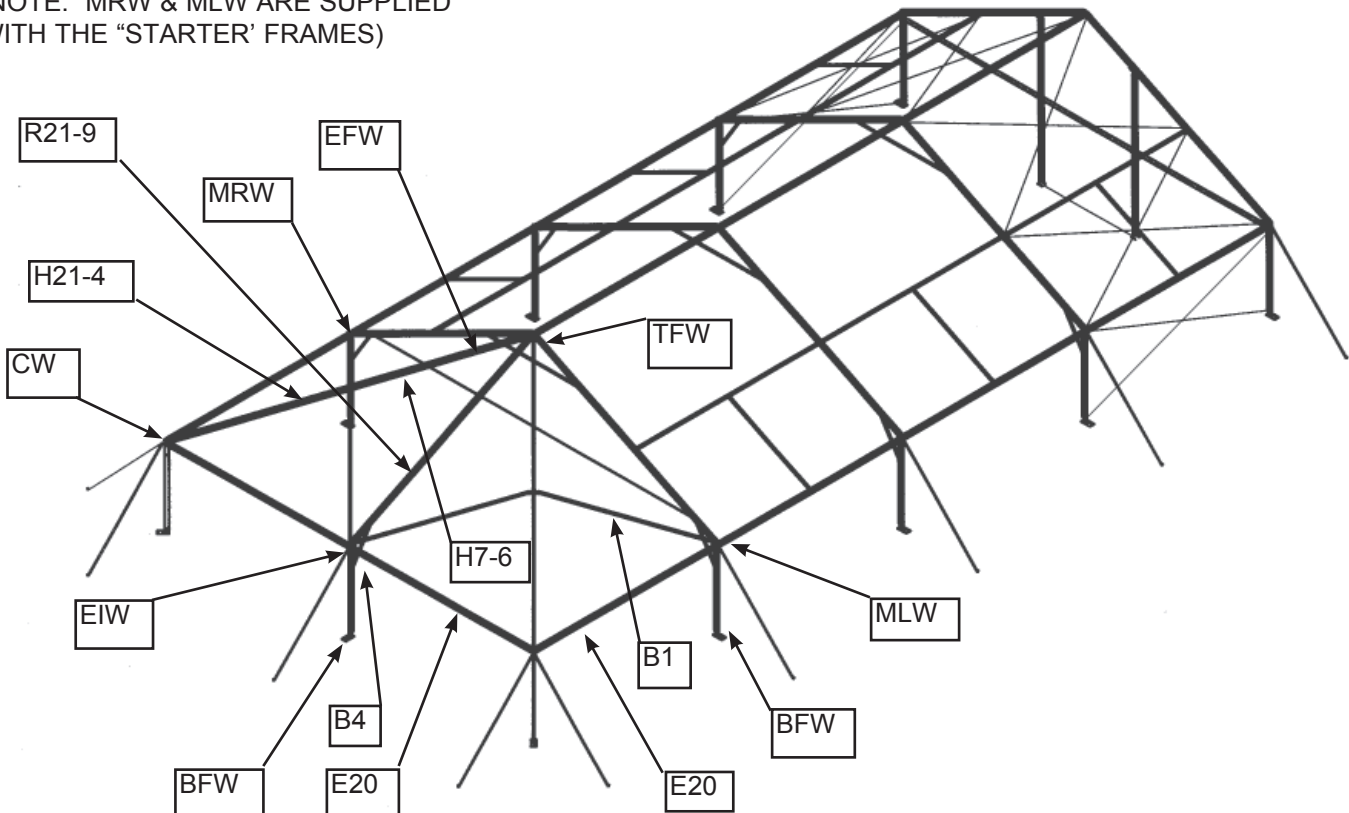

DIAGONAL BEAM BRACE USE (OPTIONAL PURCHASE)

The diagonal beam brace is an optional purchase and is used for help in raising and stabilizing the first raised beam. These are sold in sets of two and are meant to be used simultaneously on both sides of the frame.

The diagonal beam brace is adjustable and may be used on all standard sized mids and upright heights.

The first step in using the diagonal beam brace is to adjust it to the size required. Slide the bar out until you see the label for your particular mid size and upright height, then pin to size.

Insert top of beam brace into pad eye weldment and pin as shown in Figure 2.

As beam is being raised, guide bottom of brace to the base plate of the second beam. Attach brace to base plate and pin as shown in Figure 3.

Raise second beam.

Attach purlins and cables.

Remove braces.

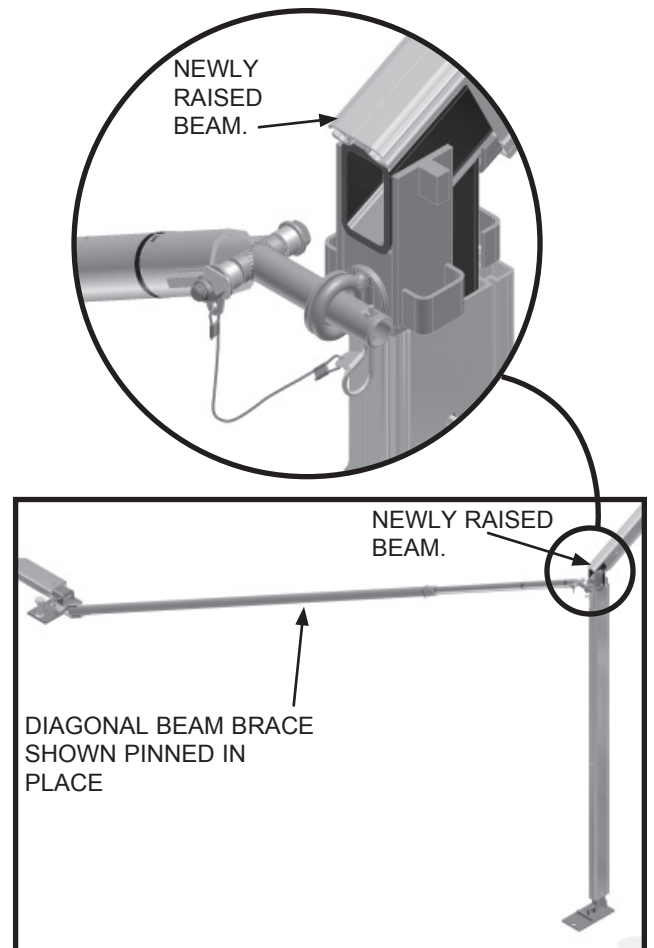
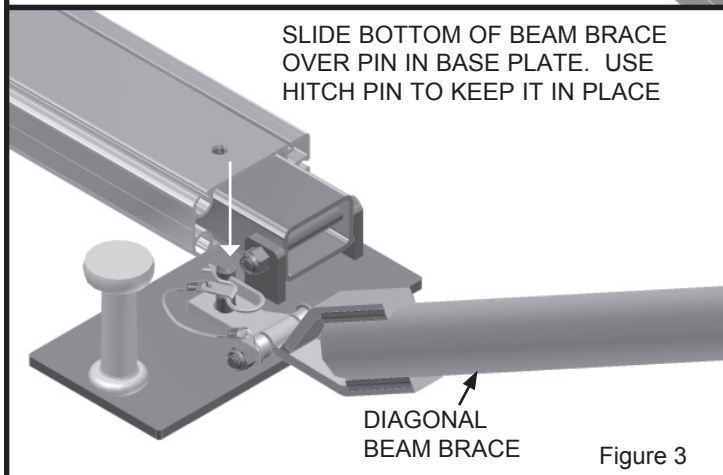
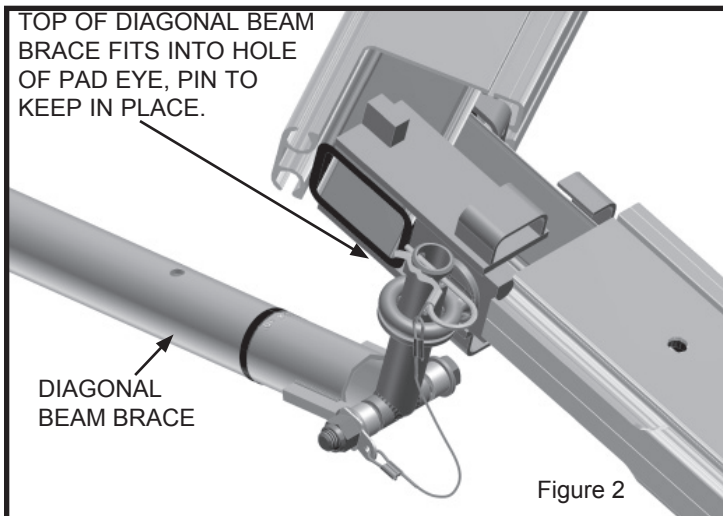
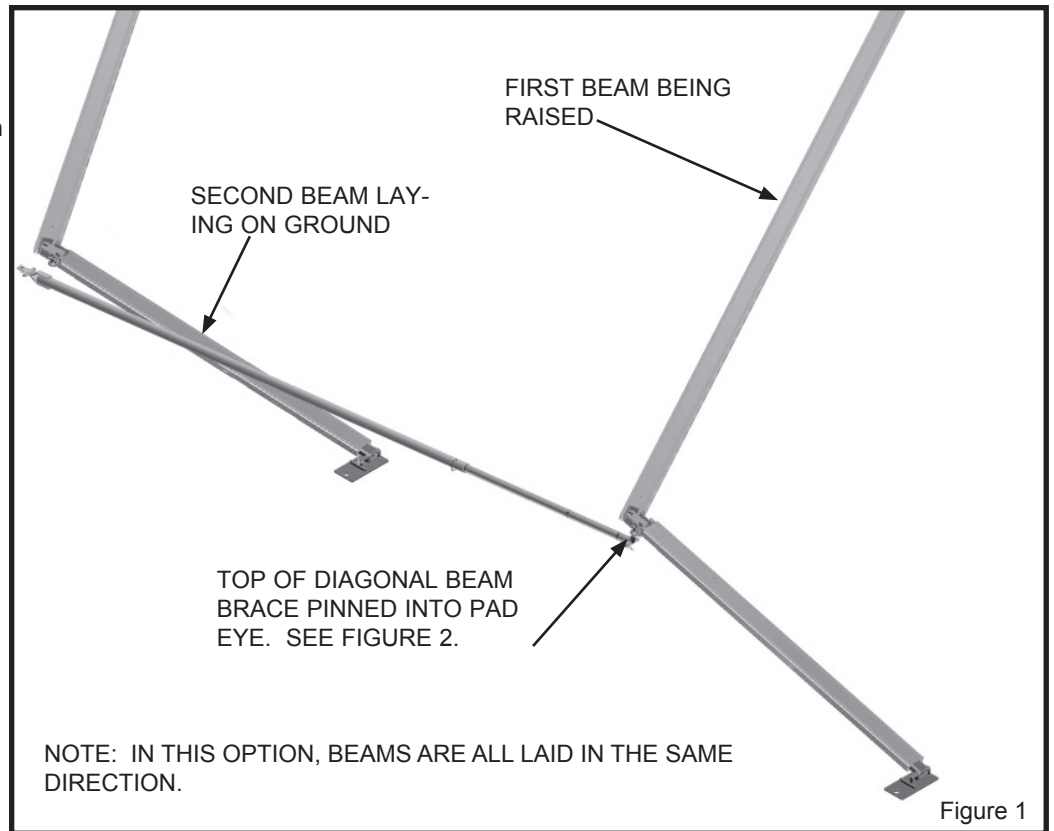

Wall Installation

Step 1

Determine which side of wall is inside and out. Ground bar pockets are on outside, Lace flap is on inside. Start by feeding top of kedar edge into channel opening until top of wall is as far as it will go. (Figure A)

Insert the bottom edge of kedar into channel opening and feed down until wall is smoothly installed into upright.

Step 2

Starting with wall tab nearest the lace, insert into slotted opening in bottom channel of eave bar. Feed rest of wall tabs into channel.

Step 3

Repeat with the matching half of the wall.

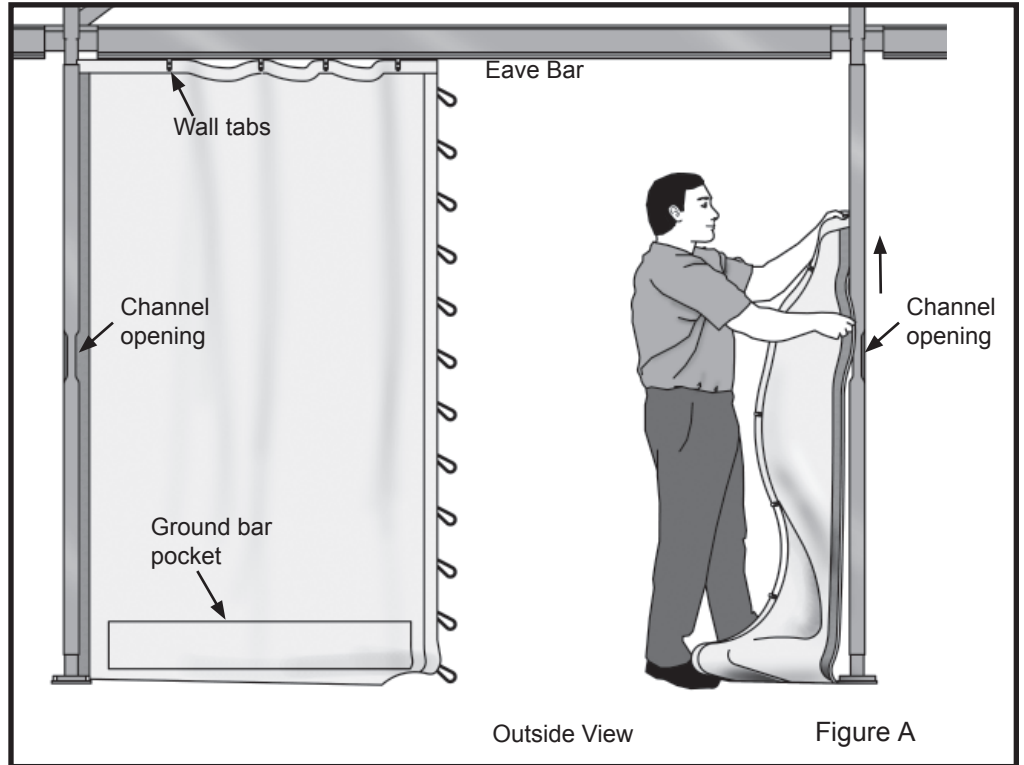

Step 4

Lace wall starting at top of wall bringing top loop thru the top grommet of matching half of wall to inside of wall. Continue with this process looping next loop thru grommet and then the upper loop until all loops are laced. (See Figure B) Tie off bottom loop to keep lace together.

Step 5

Slide ground bar (Figure C) thru pocket on outside of wall. Fasten to frame using the ground bar keeper as noted on next page.

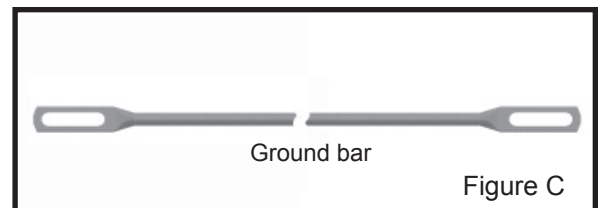
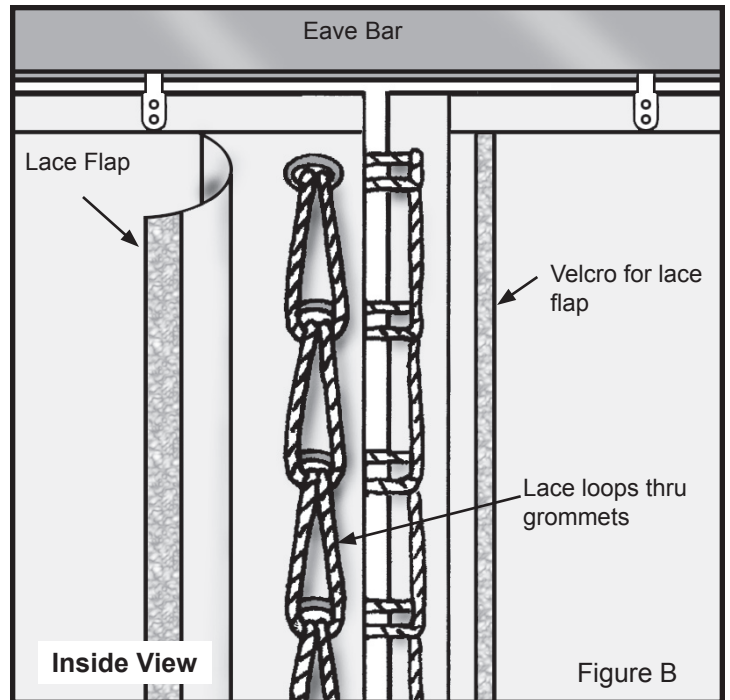

Navi-Trac Ground Bar Keeper Instructions

Upright prong fits into this part of upright.

This end to outside of tent.



Cross sectional view of upright.

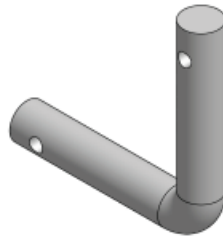

Groundbar keeper for intermediate upright.

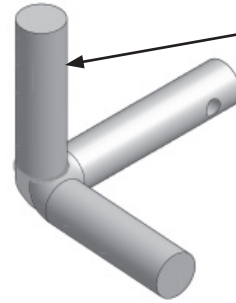

Groundbar keeper for Corners.

Prong with no hole inserts up into upright.

Wall with kedar already slid into upright.

Corner Upright

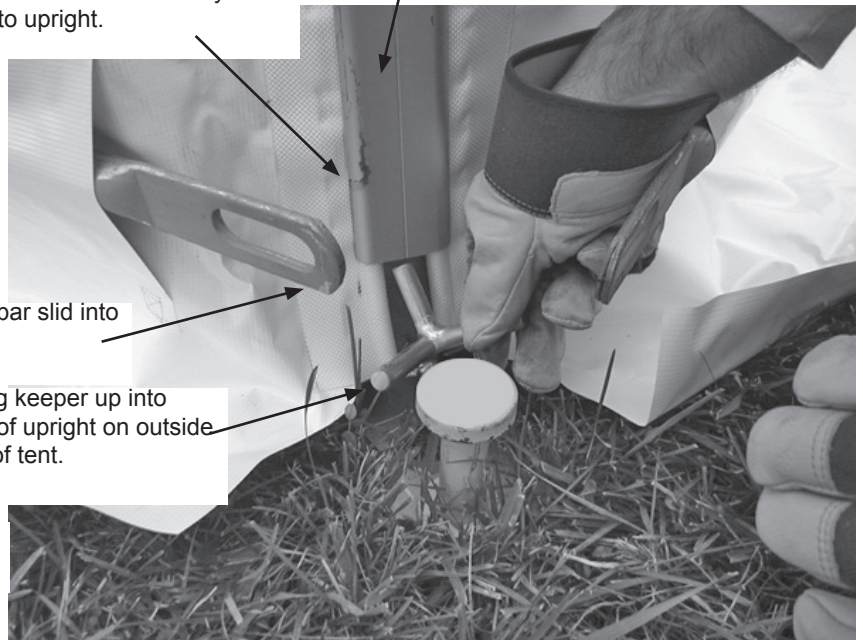

Groundbar slid into pocket.

Inserting keeper up into bottom of upright on outside corner of tent.

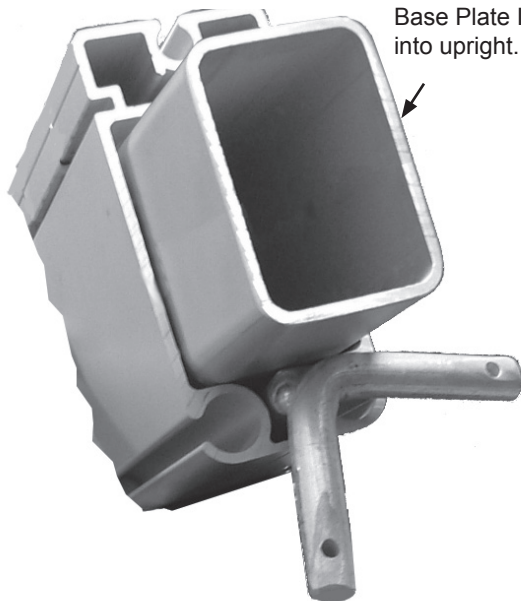

Base Plate Inserted into upright.

Bottom View looking up into upright with Groundbar keeper inserted.

Slide groundbars onto prongs and pin into place as shown.

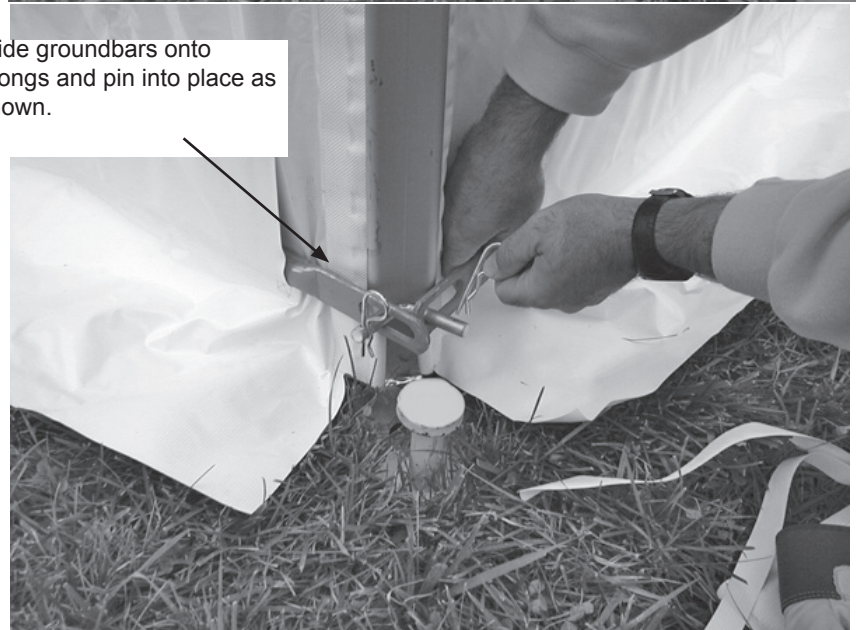



PHONE NUMBER
812 · 867 · 2421

FAX NUMBER
812 · 867 · 0547

Anchor products are of superior design and operate best within the parameters of these instructions. It is imperative that the instructions be carefully read and **COMPLETELY FOLLOWED**. Please read installation instructions before the installation or removal of this product. Installation instructions are available online at www.anchorinc.com or by calling 1-800-544-4445.

CAUTION:

1. For each installation, the installer is solely responsible for evaluating the site and the proper securing method determined. Some soils require different staking or securing than that provided with the tent. Due to this variety of soil conditions, these are the manufacturer's suggested sequence of installation procedures. Anchor's responsibility is limited to the manufacture of the tent parts and materials. We are not responsible for methods that installers may choose to erect and secure the tent to the ground.
2. The number of stakes suggested in the installation instructions do not necessarily meet all or any relevant codes on the site of the tent installation. The number of stakes suggested **will, in many cases, keep the tent erected**, however, due to various soil conditions; these stakes will be insufficient **to keep the tent secure in high winds**. It is the tent installer's responsibility, not the manufacturer, to determine the appropriate number of stakes to meet the necessary wind loads on the site. Regardless of the number of stakes we suggest, we make no representation or warranty as to whether this specific number of stakes will meet the local tent code. Anchor does not, nor can it make any suggestions, representation, or warranties about the adequate staking required at each specific installation site. Staking information provided in the installation instructions **is not a suggestion about what is necessary to meet a site-specific load**.

For additional important information, consult: "The IFAI Procedural Handbook For the Safe Installation and Maintenance of Tentage" and the IFAI Pocket Guide "Pullout Capacity of Tent Stakes", both available from the IFAI Tent Rental Division or on our website.

3. Inasmuch as the weather is unpredictable, good judgment and common sense must be incorporated within installation guidelines. It is the responsibility of the tent installer/maintainer to determine the severity of the weather, proper time and method of installation and/or erection and disassembly. **Note: We recommend that snow and ice be removed from the tent surface as soon as possible because accumulation will damage the tent or fabric structure. Please consult with our Engineering Department about the maximum loads for each product.**

This product has been manufactured to meet code requirements. For the safety of all occupants, evacuation is recommended if threatening weather occurs, or if there is any doubt concerning the safe use of this product.

4. Proper safety equipment should be used at all times to insure a safe installation and take down. We suggest a careful evaluation be made to determine safety equipment needed, such as hard hats, steel-toe shoes, safety glasses and other as required. It is our desire that all installations are safe. Please be aware of hidden dangers both underground, i.e., gas lines, water lines, electrical lines, etc. and above the tent such as power lines and telephone lines.
5. Anchor stands behind its products in accordance with its standard Terms and Conditions of sale. A copy of our Terms and Conditions of Sale can be obtained by contacting Anchor at the telephone number and/or address on this document.